

Jazzy 600

Owner's Manual



How a Power Chair Should Feel!™

Pride
Mobility Products Australia Pty. Ltd.

21 Healey Road
Dandenong, 3175
Victoria, Australia

ACN#088 609 661

www.pridemobility.com

SAFETY GUIDELINES

The symbols below are used throughout this owner's manual and on the power chair to identify warnings and important information. It is very important for you to read them and understand them completely.



WARNING! Failure to follow designated procedures can cause either personal injury, component damage, or malfunction (black symbol on yellow triangle with black border).



MANDATORY! These actions should be performed as specified. Failure to perform mandatory actions can cause injury to personnel and/or damage to equipment (white symbol on blue dot).



PROHIBITED! These actions should be prohibited. These actions should not be performed at any time or in any circumstances. Performing a prohibited action can cause injury to personnel and/or damage to equipment (black symbol with red circle and red slash).

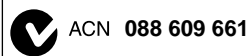

Copyright © 2005

This product is manufactured by:
Pride Mobility Products Corporation
182 Susquehanna Avenue
Exeter, PA 18643
USA

INFMANU3039/RevA/May05

C O N T E N T S

I. INTRODUCTION	4
II. SAFETY	5
III. YOUR POWER CHAIR	14
IV. ASSEMBLY	19
V. COMFORT ADJUSTMENTS	21
VI. BATTERIES AND CHARGING	27
VII. OPERATION	30
VIII. CARE AND MAINTENANCE	33
IX. WARRANTY	39

This owner’s manual is compiled from the latest specifications and product information available at the time of publication. We reserve the right to make changes as they become necessary. Any changes to our products may cause slight variations between the illustrations and explanations in this manual and the product you have purchased.

I. INTRODUCTION

SAFETY

WELCOME to Pride Mobility Products Corporation (Pride). The power chair you have purchased combines state-of-the-art components with **safety**, comfort, and styling in mind. We are confident that these design features will provide you with the conveniences you expect during your daily activities. Once you understand how to **safely** operate and care for your power chair, it should give you years of trouble free operation and service.

Read and follow all instructions, warnings, and notes in this manual before attempting to operate your power chair for the first time. In addition, your **safety** depends upon you, as well as your provider, caretaker, or healthcare professional in using good judgement.

If there is any information in this manual which you do not understand, or if you require additional assistance for setup or operation, please contact your authorised Pride Provider. **Failure to follow the instructions in this manual and those located on your power chair can lead to personal injury and/or damage to the power chair, including voiding the warranty.**

PURCHASER'S AGREEMENT

By accepting delivery of this product, you promise that you will not change, alter, or modify this product or remove or render inoperable or unsafe any guards, shields, or other safety features of this product; fail, refuse, or neglect to install any retrofit kits from time to time provided by Pride to enhance or preserve the safe use of this product.

INFORMATION EXCHANGE

We want to hear your questions, comments, and suggestions about this manual. We would also like to hear about the safety and reliability of your new power chair, and about the service you received from your authorised Pride Provider.

Please notify us of any change of address, so we can keep you apprised of important information about safety, new products, and new options that can increase your ability to use and enjoy your power chair. Please feel free to contact us at the address below:

Pride Mobility Products Australia Pty. Ltd.
21 Healey Road
Dandenong, 3175
Victoria, Australia

My authorised Pride Provider:

Name: _____

Address: _____

Phone Number: _____

Purchase Date: _____

NOTE: If you ever lose or misplace your product registration card or your copy of this manual, contact us and we will be glad to send you a new one immediately.

II. SAFETY

PRODUCT SAFETY SYMBOLS

The symbols below are used on the power chair to identify warnings, mandatory actions, and prohibited actions. It is very important for you to read and understand them completely.



Corrosive chemicals contained in battery. Use only AGM or Gel-Cell batteries to reduce the risk of leakage or explosive conditions.



Read and follow the information in the owner's manual.



Maximum seating weight.



Locked and in drive mode.

Place unit on level ground and stand behind or to one side when changing from drive mode to freewheel mode or freewheel mode to drive mode.

Unlocked and in freewheel mode.

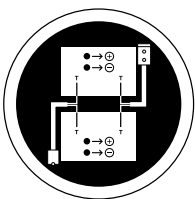

**Battery Configuration:
T = Terminal Post
Connect Red wire to T with +
Connect Black wire to T with -**

II. SAFETY



Do not use a cell phone, walkie/talkie, laptop, or other radio transmitter while operating.



Avoid exposure to rain, snow, ice, salt, or standing water whenever possible. Maintain and store in a clean and dry condition.



Removal of grounding prong can create electrical hazard. If necessary, properly install an approved 3-pronged adapter to an electrical outlet having 2-pronged plug access. Failure to heed could result in personal injury and/or property damage.

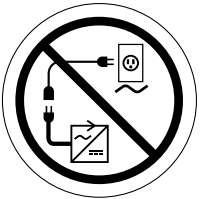

Prevent personal injury and equipment damage. Do not connect an extension lead to the AC/DC converter or the battery charger.

II. SAFETY

SAFETY



MANDATORY! Do not operate your new power chair for the first time without completely reading and understanding this owner's manual.

Your power chair is a state-of-the-art life-enhancement device designed to increase mobility. Pride provides an extensive variety of products to best fit the individual needs of the power chair user. Please be aware that the final selection and purchasing decision regarding the type of power chair to be used is the responsibility of the power chair user, who is capable of making such a decision, and his/her healthcare professional (i.e., medical doctor, physical therapist, etc.).

The contents of this manual are based on the expectation that a mobility device expert has properly fitted the power chair to the user and has assisted the prescribing healthcare professional and/or the authorised Pride Provider in the instruction process for the use of the product.

There are certain situations, including some medical conditions, where the power chair user will need to practice operating the power chair in the presence of a trained attendant. A trained attendant can be defined as a family member or care professional specially trained in assisting a power chair user in various daily living activities.

As you begin using your power chair during daily activities, you will probably encounter situations in which you will need some practice. Simply take your time and you will soon be in full and confident control as you maneuver through doorways, on and off of lifts, up and down ramps, and over moderate terrain.

Below are some precautions, tips, and other safety considerations that will help the user become accustomed to operating the power chair safely.

Modifications

Pride has designed and engineered your power chair to provide maximum mobility and utility. A wide range of accessories is available from your authorised Pride Provider to further customize your power chair to better suit your needs and/or preferences. However, under no circumstances should you modify, add, remove, or disable any feature, part, or function of your power chair.



WARNING! Do not modify your power chair in any way not authorised by Pride. Unauthorised modifications may result in personal injury and/or damage to your power chair.

Pre-Ride Safety Check

Get to know the feel of your power chair and its capabilities. Pride recommends that you perform a safety check before each use to make sure your power chair operates smoothly and safely.

Perform the following inspections prior to using your power chair:

- Check for proper tyre inflation. Maintain but do not exceed **2.4 bar** in each tyre (if equipped with pneumatic tyres).
- Check all electrical connections. Make sure they are tight and not corroded.
- Check all controller connections to the power base. Make sure they are secured properly.
- Check the brakes. See VIII. "Care and Maintenance."
- Check battery charge. See VI. "Batteries and Charging."

NOTE: If you discover a problem, contact your authorised Pride Provider for assistance.

II. SAFETY

Weight Limitations

Your power chair is rated for a maximum weight capacity. Please refer to the specifications table for this limit.



WARNING! Exceeding the weight capacity voids your warranty and may result in personal injury and/or damage to your power chair. Pride will not be held responsible for injuries and/or property damage resulting from failure to observe weight limitations.

WARNING! Do not carry passengers on your power chair. Carrying passengers on your power chair may result in personal injury and/or property damage.

Tyre Inflation

If your power chair is equipped with pneumatic tyres, you should check or have the air pressure checked regularly. Proper inflation pressures will prolong the life of your tyres and help ensure the smooth operation of your power chair.



WARNING! It is important that 2.4 bar tyre pressure be maintained in pneumatic tyres at all times. Do not underinflate or overinflate your tyres. Low pressure may result in loss of control, and overinflated tyres may burst. Failure to maintain 2.4 bar tyre pressure in pneumatic tyres at all times may result in tyre and/or wheel failure, causing serious personal injury and/or damage to your power chair.

WARNING! Inflate your power chair drive tyres from a regulated air source with an available pressure gauge. Inflating your tyres from an unregulated air source could overinflate them, resulting in a burst tyre and/or personal injury.

Incline Information

More and more buildings have ramps with specified degrees of inclination, designed for easy and safe access. Some ramps may have turning switchbacks (180-degree turns) that require you to have good cornering skills on your power chair.

- Proceed with extreme caution as you approach the downgrade of a ramp or other incline.
- Take wide swings with your power chair's front wheels around any tight corners. If you do that, the power chair's rear wheels will follow a wide arc, not cut the corner short, and not bump into or get hung up on any railing corners.
- When driving down a ramp, keep the power chair's speed adjustment set to the slowest speed setting to ensure a safely controlled descent. See VII. "Operation."
- Avoid sudden stops and starts.

When climbing an incline, try to keep your power chair moving. If you must stop, start up again slowly and then accelerate cautiously. When driving down an incline, set your power chair to the slowest setting and drive in the forward direction only. If your power chair starts to move down the incline faster than you anticipated or desired, allow it to come to a complete stop by releasing the joystick, then push the joystick forward slightly to ensure a safely controlled descent.

WARNING! When climbing an incline, do not zigzag or drive at an angle up the face of the incline. Drive your power chair straight up the incline. This greatly reduces the possibility of a tip or a fall. Always exercise extreme caution when negotiating an incline.



WARNING! You should not travel up or down a potentially hazardous incline (i.e., areas covered with snow, ice, cut grass, or wet leaves).

WARNING! When on any sort of an incline or decline, never place the power chair in freewheel mode while seated on it or standing next to it. Doing so may result in personal injury and/or damage to your power chair.

WARNING! Never travel down an incline rearwards. This may result in personal injury.

II. SAFETY



WARNING! Even though your power chair is capable of climbing slopes greater than those illustrated in figure 1, do not, under any circumstances, exceed the incline guidelines or any other specifications presented in this manual. Doing so could cause instability in your power chair, resulting in personal injury and/or damage to your power chair.

Most handicap public access ramps are required to have a maximum slope of 8.7% (5°). Therefore, Pride recommends that the maximum slope of an incline you attempt to safely ascend or descend on your power chair does not exceed 8.7% (5°). See figure 1.



WARNING! Any attempt to climb or descend a slope steeper than 8.7% (5°) may put your power chair in an unstable position and cause it to tip, resulting in personal injury.

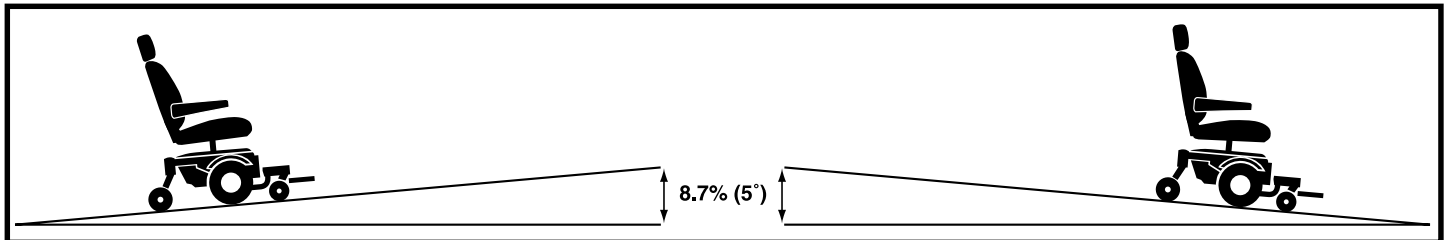

Figure 1. Maximum Safe Slope (Ascending and Descending)

Braking Information

Your power chair is equipped with two powerful brake systems:

1. Regenerative — uses electricity to rapidly slow the vehicle when the joystick returns to the centre/stop position.
2. Disc Park Brake — activates mechanically after regenerative braking slows the vehicle to near stop, or when power is removed from the system for any reason.

Cornering Information

While your power chair is equipped with four caster wheels, excessively high cornering speeds can still create the possibility of tipping. Factors which affect the possibility of tipping include, but are not limited to: cornering speed, steering angle (how sharply you are turning), uneven road surfaces, inclined road surfaces, riding from an area of low traction to an area of high traction (such as passing from a grassy area to a paved area — especially at high speed while turning), and abrupt directional changes. High cornering speeds are not recommended. If you feel that you may tip over in a corner, reduce your speed and steering angle (i.e., lessen the sharpness of the turn) to prevent your power chair from tipping.



WARNING! When cornering sharply, reduce your speed. This greatly reduces the possibility of a tip or fall. To avoid personal injury and/or property damage, always exercise common sense when cornering.

Public Streets and Roadways



WARNING! You should not operate your power chair on public streets and roadways. Be aware that it may be difficult for traffic to see you when you are seated on your power chair. Obey all local pedestrian traffic rules. Wait until your path is clear of traffic, and then proceed with extreme caution.

Removable Parts



WARNING! Do not attempt to lift or move a power chair by any of its removable parts. Personal injury and/or damage to the power chair may result.

II. SAFETY

Freewheel Mode

Your power chair is equipped with two manual freewheel levers to allow for manual maneuverability by a trained attendant. For more information about how to place your power chair into and out of freewheel mode, see III. “Your Power Chair.”

WARNING! Do not use your power chair in freewheel mode without an attendant present. Personal injury may result.



WARNING! Do not attempt to personally place your power chair in freewheel mode while seated on it. Personal injury may result. Ask an attendant for assistance if necessary.

WARNING! Do not place your power chair in freewheel mode while on an incline. The chair could roll uncontrollably on its own, causing personal injury.

Outdoor Driving Surfaces

Your power chair is designed to provide optimum stability under normal driving conditions—dry, level surfaces composed of concrete, blacktop, or tarmac. However, Pride recognizes that there will be times when you will encounter other surface types. For this reason, your power chair is designed to perform admirably on packed soil, grass, and gravel. Feel free to use your power chair safely on lawns and in park areas.

- Reduce your power chair’s speed when driving on uneven terrain and/or soft surfaces.
- Avoid tall grass that can entangle the running gear.
- Avoid loosely packed gravel and sand.
- If you feel unsure about a driving surface, avoid that surface.

Stationary Obstacles (Steps, Kerbs, etc.)

Proceed with extreme caution when driving near raised surfaces, unprotected ledges and/or drop-offs (kerbs, porches, stairs, etc.). The correct method for approaching a kerb is illustrated in figures 2 and 3.

WARNING! Do not attempt to have your power chair climb or descend an obstacle that is higher than 5 cm unless you have the assistance of an attendant.



WARNING! Do not attempt to have your power chair proceed rearwards down any step, kerb, or other obstacle. This may cause the power chair to tip and cause personal injury.

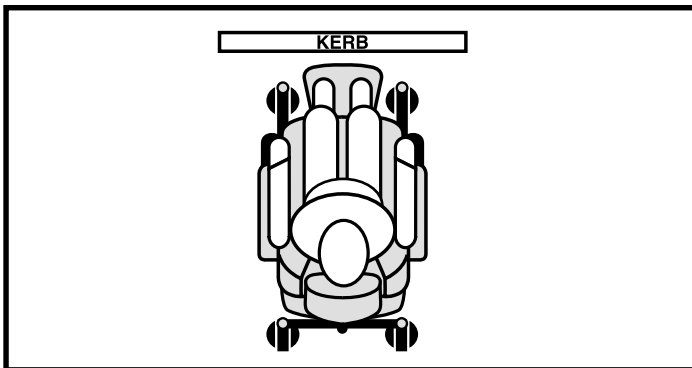

Figure 2. Correct Kerb Approach

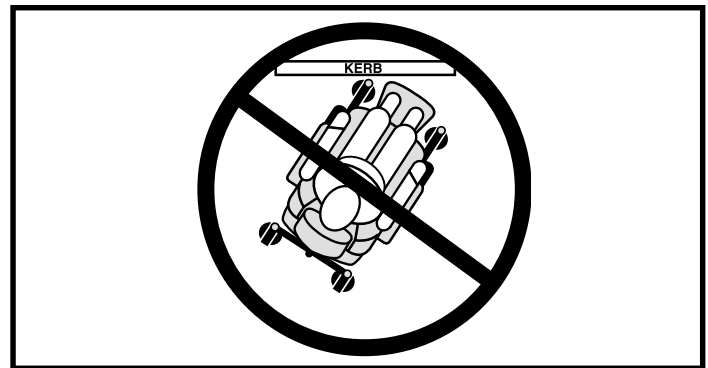

Figure 3. Incorrect Kerb Approach

Stairs and Escalators

Power chairs are not designed to travel up or down stairs or escalators. Always use a lift.



WARNING! Never use your power chair to negotiate steps or escalators. You may cause injury to yourself and to others and/or damage your power chair.

II. SAFETY

Transfers

Transferring onto and off of your power chair requires a good sense of balance. Always have an attendant or health-care professional present while learning to properly transfer yourself.

To eliminate the possibility of injury, Pride recommends that you or a trained attendant perform the following tasks before attempting a transfer:

- Turn the power off. See VII. “Operation.”
- Ensure your power chair is not in freewheel mode. See III. “Your Power Chair.”
- Turn the caster wheels toward the transfer destination to improve power chair stability during transfer.
- Make sure both armrests are flipped up or removed from your power chair.
- Flip up the foot platform or move the leg rests aside; this will help to keep your feet from getting caught on the foot rigging during the transfer.
- Reduce the distance between your power chair and the object you are transferring onto.

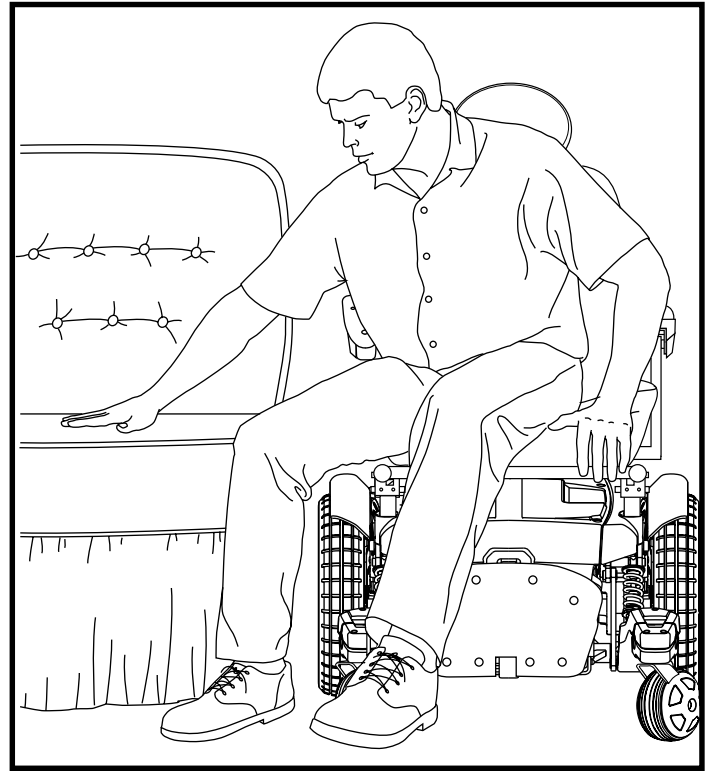

Figure 4. Ideal Transfer Position

WARNING! Before transferring, position yourself as far back as possible in the power chair seat to prevent the power chair from tipping forward during transfer and causing injury.



WARNING! Avoid using your armrests for weight bearing purposes. Such use may cause the power chair to tip and cause personal injury.

WARNING! Avoid putting all of your weight on the foot riggings. Such use may cause the power chair to tip and cause personal injury.

Doors

- Determine if the door opens toward or away from you.
- Drive your power chair gently and slowly forward to push the door open. Or drive your power chair gently and slowly rearwards to pull the door open.

Lifts

Modern lifts have a door edge safety mechanism that, when pushed, reopens the lift door(s).

- If you are in the doorway of a lift when the door(s) begin to close, push on the rubber door edge or allow the rubber door edge to contact the power chair and the door will reopen.
- Use care that handbags, packages, or power chair accessories do not become caught in lift doors.

Lift/Elevation Products

If you will be traveling with your power chair, you may find it necessary to use a lift/elevation product to aid in transportation. Pride recommends that you closely review the instructions, specifications, and safety information set forth by the manufacturer of the lift/elevation product before using that product.

II. SAFETY

Inclement Weather Precautions

Exposure of your power chair to inclement weather conditions should be avoided whenever possible. If suddenly caught up in rain, snow, severe cold or heat while operating your power chair proceed to shelter at the earliest opportunity. Thoroughly dry your power chair before storing, charging, or operating your power chair.



WARNING! Operating in rain, snow, salt, mist/spray conditions, and on icy/slippery surfaces can cause personal injury and/or damage to the power chair and electrical system. Maintain and store your power chair in a dry and clean condition.

Motor Vehicle Transport

Currently, there are no standards approved for tie-down systems in a moving vehicle of any type to transport a person while seated in a power chair.



WARNING! Do not sit on your power chair while it is in a moving vehicle. Personal injury and/or property damage may result.

WARNING! Always be sure your power chair and its batteries are properly secured when it is being transported. Failure to do so may result in personal injury and/or damage to your power chair.

Positioning Belts

Your authorised Pride Provider, therapist(s), and other healthcare professionals are responsible for determining your requirement for a positioning belt in order to operate your power chair safely.



WARNING! If you require a positioning belt to safely operate your power chair, make sure it is fastened securely. Serious personal injury may result if you fall from the power chair.

WARNING! The positioning belt is not designed for use as a seat belt in a motor vehicle. Nor is your power chair suitable for use as a seat in any vehicle. Anyone traveling in a vehicle should be properly belted into seats approved by the vehicle manufacturer.

Reaching and Bending

Never reach, lean, or bend while driving your power chair. If it is absolutely necessary to reach, lean, or bend while seated on your power chair, it is important to maintain a stable centre of gravity and keep the power chair from tipping. Pride recommends that the power chair user determine his/her personal limitations and practice bending and reaching in the presence of a qualified healthcare professional.



WARNING! Do not bend, lean, or reach for objects if you have to pick them up from the floor by reaching down between your knees. Movements such as these may change your centre of gravity and the weight distribution of the power chair. This may cause your power chair to tip, possibly resulting in personal injury.

WARNING! Prevent personal injury! Keep your hands away from the tyres when driving. Be aware that loose fitting clothing can become caught in drive tyres.

Batteries

In addition to following the warnings below, be sure to comply with all other battery handling information. For more information about your power chair's batteries, see VI. "Batteries and Charging."



WARNING! Power chair batteries are heavy. See specifications table. If you are unable to lift that much weight, be sure to get help. Lifting beyond your capacity can result in personal injury.

WARNING! Battery posts, terminals, and related accessories contain lead and lead compounds. Wash hands after handling.

II. SAFETY



WARNING! Always protect the batteries from freezing and never charge a frozen battery. Charging a frozen battery may result in personal injury and/or damage to the battery.

Preventing Unintended Movement



WARNING! If you anticipate being seated in a stationary position for an extended period of time, turn off the power. This will prevent unexpected motion from inadvertent joystick contact. This will also eliminate the possibility of unintended chair movement from electromagnetic (EM) sources. Failure to do so may result in personal injury.

Prescription Drugs/Physical Limitations

Users must exercise care and common sense when operating a power chair. This includes awareness of safety issues when taking prescribed or over-the-counter drugs or when the user has specific physical limitations.



WARNING! Consult your physician if you are taking prescribed or over-the-counter medication or if you have certain physical limitations. Some medications and limitations may impair your ability to operate your power chair in a safe manner.

Alcohol

The power chair user must exercise care and common sense when operating his/her power chair. This includes awareness of safety issues while under the influence of alcohol.



WARNING! Do not operate your power chair while you are under the influence of alcohol, as this may impair your ability to operate your power chair in a safe manner.

Electromagnetic and Radio Frequency Interference (EMI/RFI)



WARNING! Laboratory tests have shown that electromagnetic and radio frequency waves can have an adverse affect on the performance of electrically-powered mobility vehicles.

Electromagnetic and Radio Frequency Interference can come from sources such as cellular phones, mobile two-way radios (such as walkie-talkies), radio stations, TV stations, amateur radio (HAM) transmitters, wireless computer links, microwave signals, paging transmitters, and medium-range mobile transceivers used by emergency vehicles. In some cases, these waves can cause unintended movement or damage to the control system. Every electrically-powered mobility vehicle has an immunity (or resistance) to EMI. The higher the immunity level, the greater the protection against EMI. This product has been tested and has passed at an immunity level of 20 V/m.



PROHIBITED! To prevent unintended movement, turn off the power to the electrically-powered mobility vehicle before using a cell phone, two-way radio, lap-top, or any other type of radio transmitter. Avoid coming into close proximity of radio or TV stations.



WARNING! The addition of accessories or components to the electrically-powered mobility vehicle can increase the susceptibility of the vehicle to EMI. Do not modify your power chair in any way not authorised by Pride.

WARNING! The electrically-powered mobility vehicle itself can disturb the performance of other electrical devices located nearby, such as alarm systems.

NOTE: For further information on EMI/RFI, go to the Resource Centre on www.pridemobility.com. If unintended motion or brake release occurs, turn your power chair off as soon as it is safe to do so. Contact your authorised Pride Provider to report the incident.

III. YOUR POWER CHAIR

THE JAZZY 600

The Jazzy 600 has two main assemblies: the seat assembly and the power base assembly. See figure 5. Typically, the seat assembly includes the armrests, seatback, and seat base. The power base assembly includes two motor/brake assemblies, two drive wheels, four caster wheels, two batteries, and wiring harnesses. See figure 5, 6, and 7.

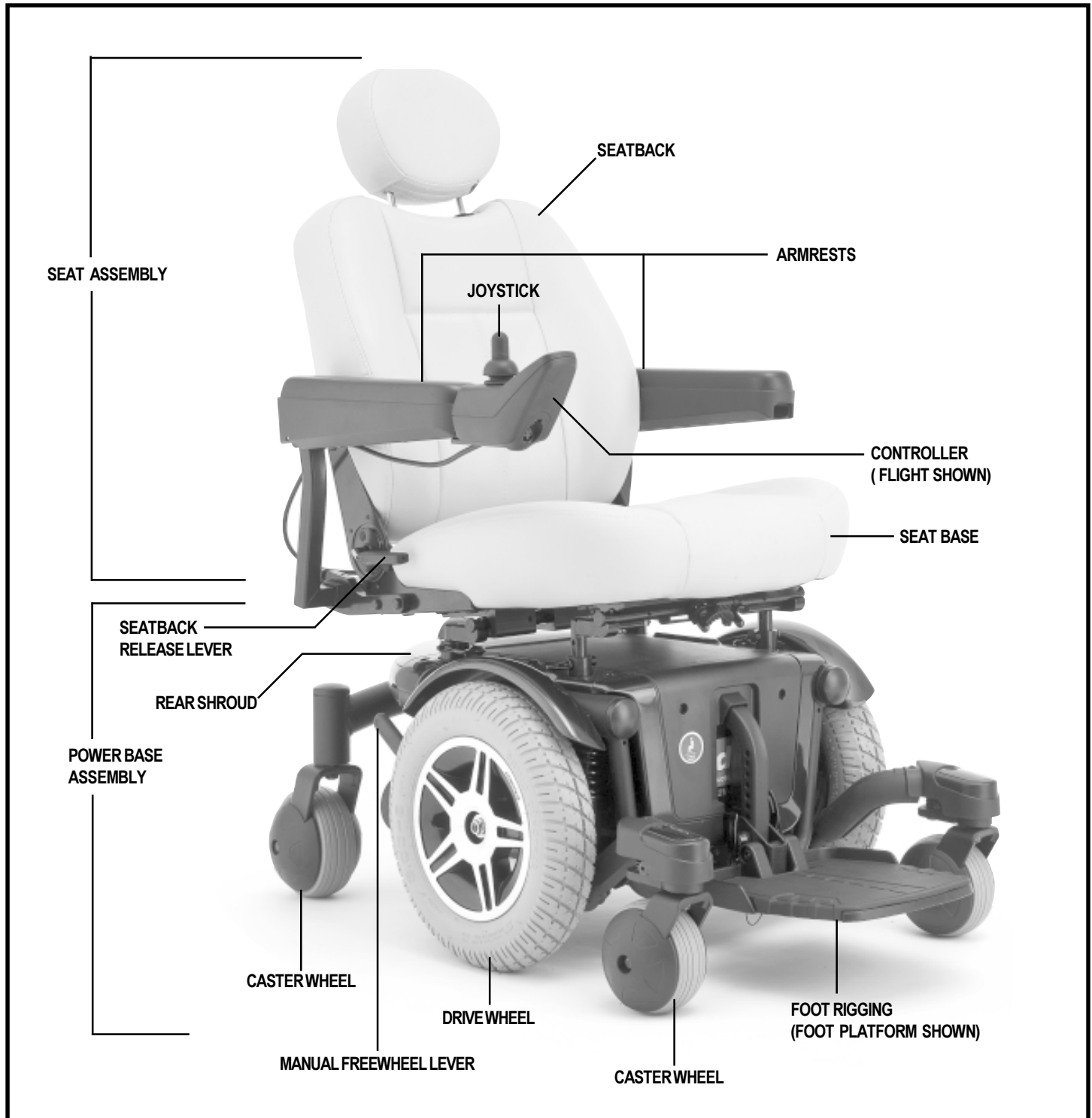

Figure 5. The Jazzy 600

III. YOUR POWER CHAIR

JAZZY 600 SPECIFICATIONS	
Class of Use:	B
Maximum Safe Slope:	8.7% (5°)
Maximum Climbing Ability:	8.7% (5°)
Maximum Obstacle Climbing Ability:	5 cm
Suspension:	Active-Trac Extreme
Drive Wheels:	35.5 cm, pneumatic (35.56 solid optional)
Front Caster Wheels:	13 cm, solid
Rear Caster Wheels:	15.25 cm, solid
Maximum Speed:	Up to 8 km/h*
Brakes:	"Intelligent Braking" electronic regenerative, disc park brake
Ground Clearance:	8 cm
Turning Radius:	49.5 cm (without foot riggings)
Overall Size:	Length: 89.5 cm (without foot riggings) Length: 97 cm (with swing-away footrests) Width: 60 cm
Seating Options:	Limited Recline High-Back Seat Full Recline High-Back Seat
Drivetrain:	Two motor, mid-wheel drive
Batteries:	Two 12-volt, NF-22 batteries
Range:	Up to 40 km*
Battery Charger:	Off-board
Electronics:	75-amp Pride Flight Controller
Weight Capacity:	136 kg
Component Weights:	Base: 55 kg Seat: 20 kg Batteries: 17.25 kg each

*Depending on user weight and terrain.

III. YOUR POWER CHAIR

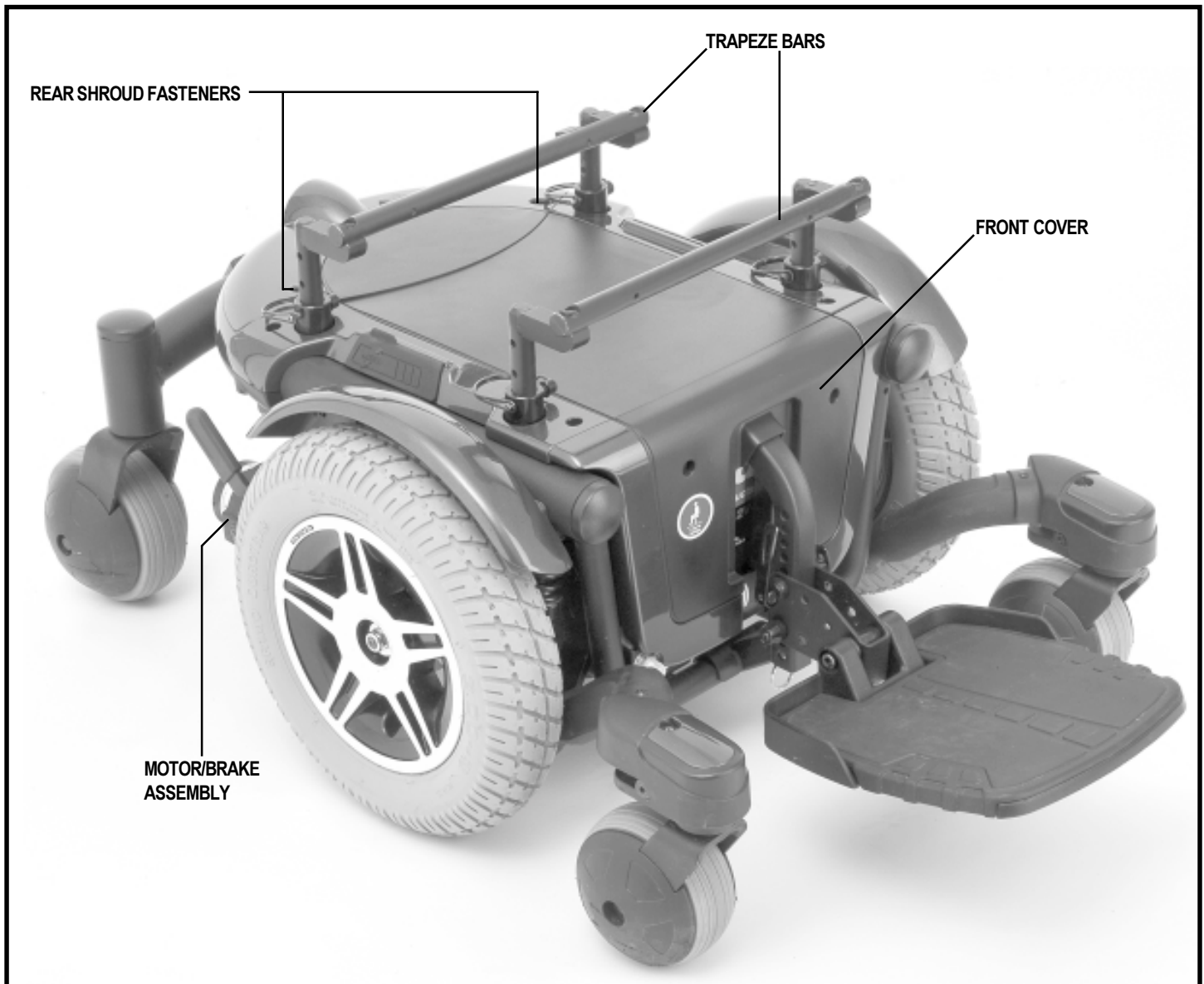

Figure 6. The Jazzy 600 Power Base

ELECTRICAL COMPONENTS

The electrical components are located inside the power base. The main circuit breaker is located on the front of the battery tray. The controller connector(s) are located inside the power base. See figure 7.

Motor Connectors: This is where the power module connects to the motors.

Battery Connector: This is where the power module connects to the batteries.

Controller Connector: This is where the controller connects to the power module.

III. YOUR POWER CHAIR

Main Circuit Breaker: The main circuit breaker is a safety feature built into your power chair. When the batteries and the motors are heavily strained (e.g., from excessive loads), the main circuit breaker trips to prevent damage to the motors and the electronics. If the circuit trips, allow your power chair to “rest” for approximately one minute. Next, push in the circuit breaker button, turn on the controller, and continue normal operation. If the main circuit breaker continues to trip repeatedly, contact your authorised Pride Provider.

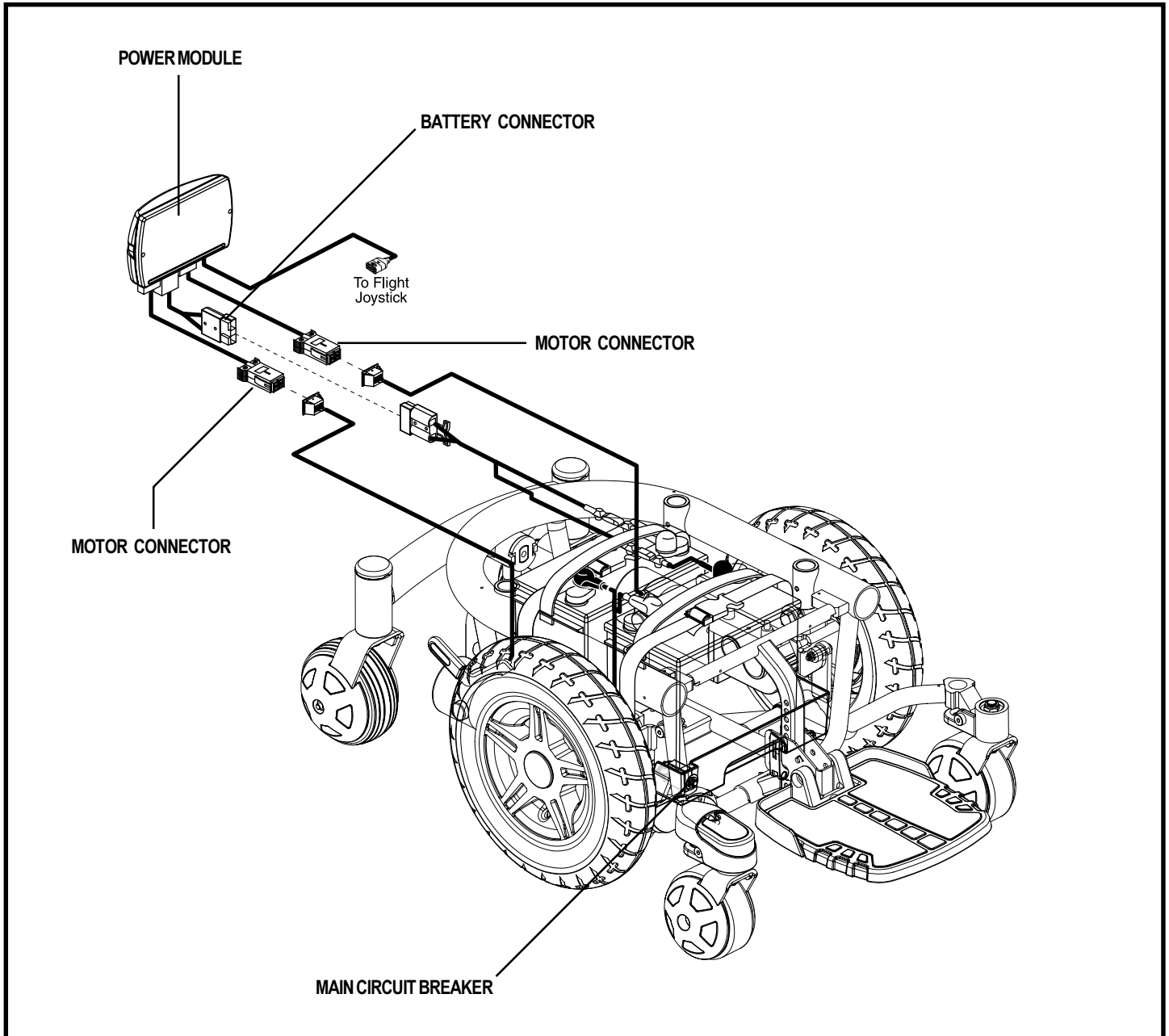

Figure 7. Jazy 600 Electrical Components

III. YOUR POWER CHAIR

MANUAL FREEWHEEL LEVERS

The Jazzy 600 has a manual freewheel lever on each motor. Manual freewheel levers enable you to disengage the drive motors from the gearboxes and maneuver the chair manually.



WARNING! Do not use the power chair while the drive motors are disengaged! Do not disengage the drive motors when the power chair is on an incline, as the unit could roll on its own, causing injury!

To engage or disengage the drive motors:

1. Locate the lever on top of each motor.
2. Pull the two levers upward to engage the drive motors. See figure 8.
3. Push the two levers downward to disengage the drive motors. See figure 9.

If a lever is difficult to move in either direction, slightly rock the power chair back and forth. The lever should then move to the desired position.



WARNING! It is important to remember that when your power chair is in freewheel mode, the braking system is disengaged.

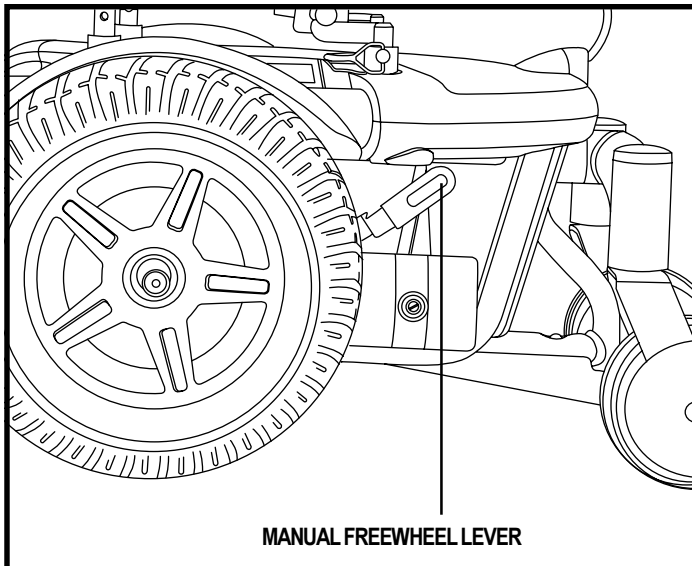

Figure 8. Drive Mode (Drive Engaged)

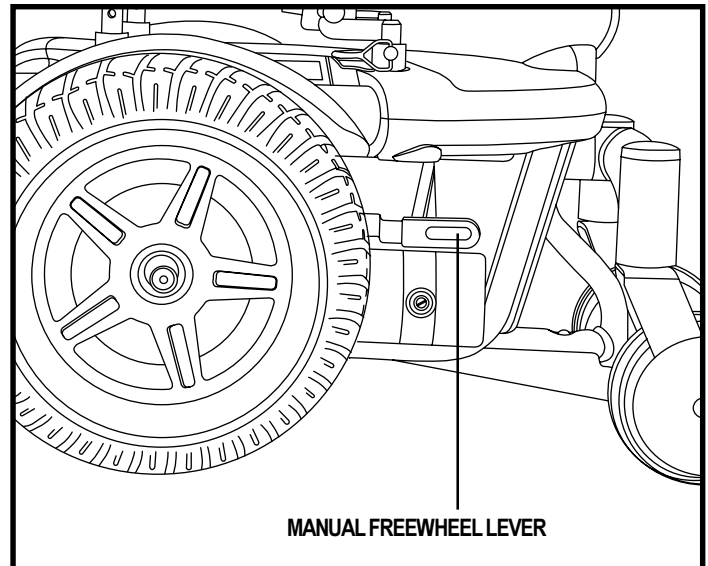

Figure 9. Freewheel Mode (Drive Disengaged)

IV. ASSEMBLY

INITIAL ASSEMBLY

Your power chair may require some assembly either before initial use or after transportation. It may also require disassembly to make some comfort adjustments. Figure 10 details those parts of the power chair that are designed to be disassembled and assembled by an end user or by a qualified carer before using the product or making comfort adjustments.

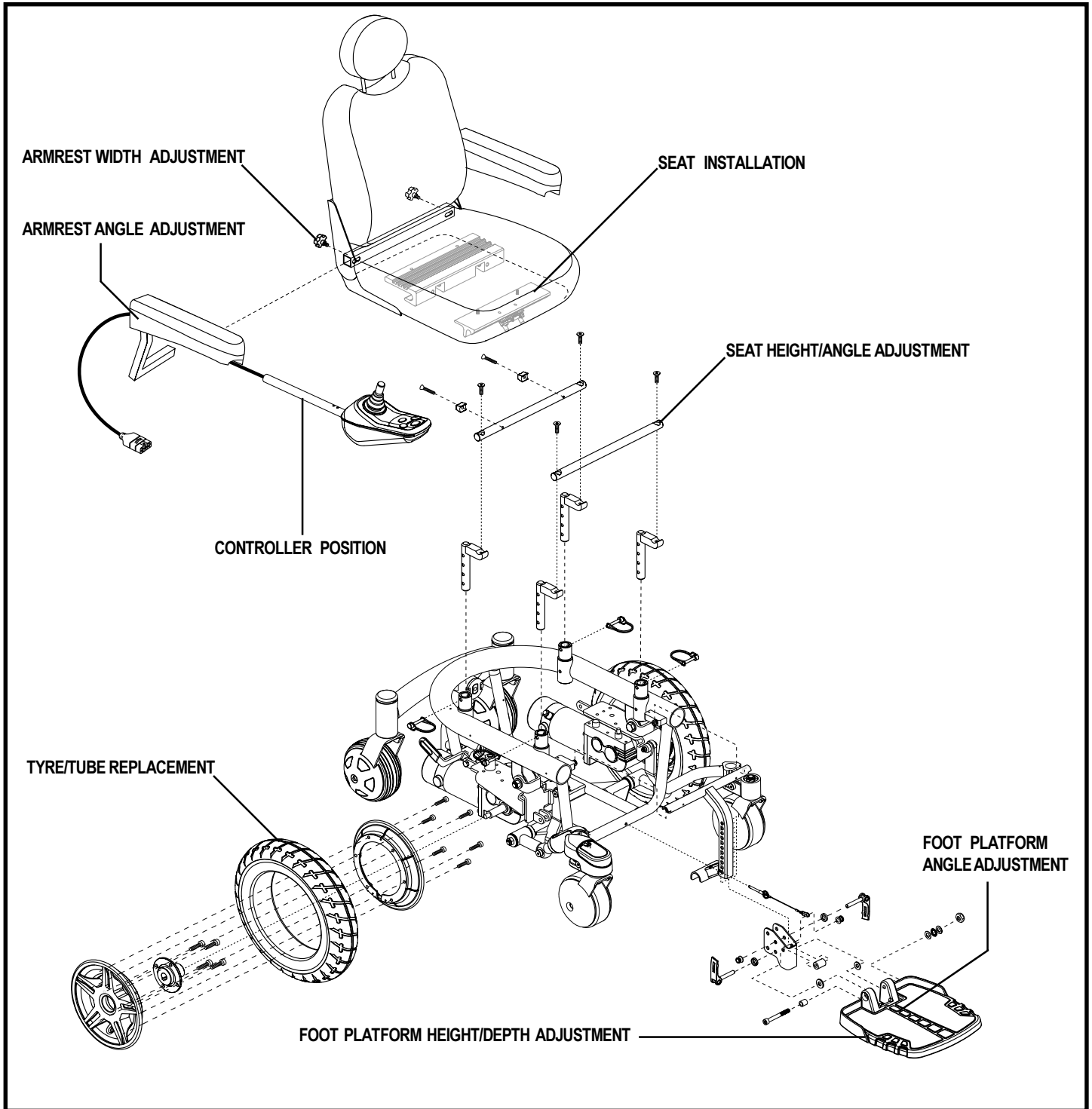

Figure 10. Jazzy 600 Assembly View

IV. ASSEMBLY

SEAT INSTALLATION

It may be necessary to install the seat either prior to initial operation or after transporting your power chair. Most seats are attached to the power base with the Universal Mounting System (UMS). The UMS consists of universal parts that may be attached to any medium-back or high-back seat, regardless of seat width or seat depth. The two main components are aluminum extrusions mounted to the seat base. These extrusions attach to a pair of trapeze bars that are mounted to the power base. See figure 11.



WARNING! Do not pick up the seat frame by the armrests. They are free to pivot, and you may lose control of the seat if they do so, resulting in personal injury or damage to the chair.

To install the seat:

1. Tilt the seat back and slide the rear extrusion onto the rear trapeze bar. See figure 11.
3. Lower the front extrusion onto front trapeze bar until the seat locks into place.
4. Flip the seat latch safety down. See figure 11a.



WARNING! Make sure the seat latch safety is flipped down before using your power chair.

5. Install the controller into one of the armrests. See figure 11. Tighten the setscrew.
6. Turn the rear shroud fasteners one-quarter turn in any direction. See figure 6.
7. Remove the rear shroud.
8. Plug the controller connector into the power base. See figure 7.
9. Reinstall the rear shroud. Turn the rear shroud fasteners one-quarter turn in any direction.
10. Route the controller cable so that it cannot be pinched in the seat hinge.
11. Secure the controller cable to the armrest receiver with one or more wire ties.

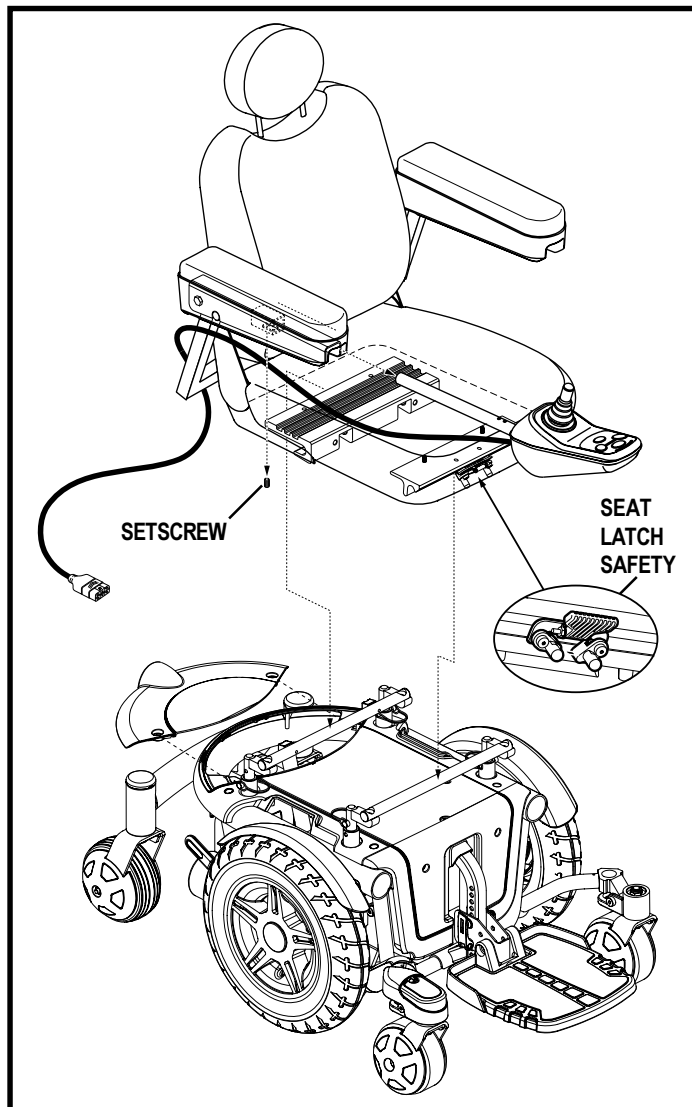

Figure 11. Seat Installation (UMS)

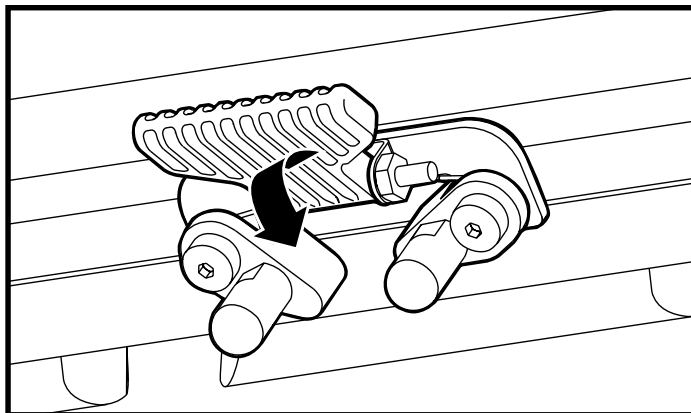

Figure 11a. Seat Installation (Seat Latch Safety)

V. COMFORT ADJUSTMENTS

COMFORT ADJUSTMENTS

After becoming familiar with your power chair's operation, you may find the need to make some adjustments to increase your comfort, such as seat height and angle, armrest angle, foot platform height and angle, and controller position.

WARNING! If your power chair was configured by your authorised Pride Provider, please consult your healthcare professional before changing the seat position or making any other adjustment. Some adjustments may degrade your power chair's performance and safety by changing its centre of gravity.



WARNING! Some power chair components are heavy. You may need assistance to lift or carry them. Please refer to the specifications table for specific component weights before you disassemble the power chair.

WARNING! Prevent injury. Remove the occupant from the power chair before making any adjustments.

You may need the following to make comfort adjustments:

- metric/standard socket set and ratchet
- adjustable spanner
- thread lock

Seat Height and Seat Angle Adjustment

You can change the seat height to one of four positions in 2.5 cm increments by raising the front and rear trapeze bars. If you raise or lower only one trapeze bar (front or rear), you can also change the seat base angle (dump).

To change the seat height:

1. Turn off the power to the controller.
2. Turn the rear shroud fasteners one-quarter turn in any direction and remove the rear shroud cover. See figure 6.
3. Disconnect the controller connector from the power base. See figure 7.
4. Flip up the seat latch safety. See figure 12.
5. Squeeze the seat latch and release the seat from the front trapeze bar.
6. Slide the seat forward and remove it from the power base.
7. Loosen the screws that attach the trapeze bars to the seat posts. See figure 13.
8. Remove the retaining clips that secure the seat posts to the power base. See figure 13.
9. Move the trapeze bars up or down to the desired height.

NOTE: Change the seat dump by raising or lowering only one set of towers (front or back).

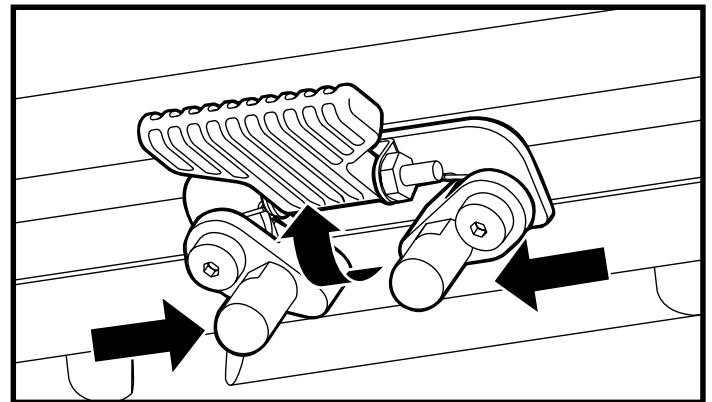

Figure 12. Seat Latch Safety

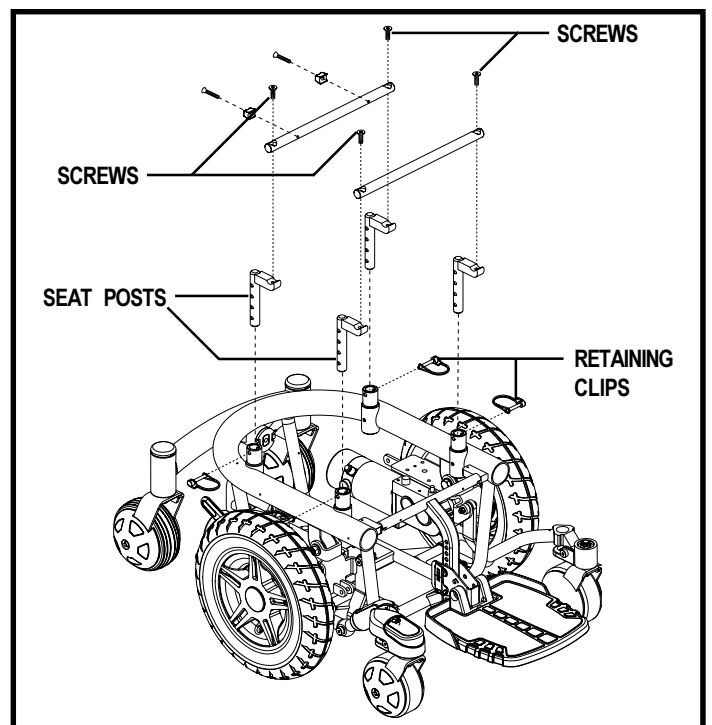

Figure 13. Trapeze Bar Adjustment

V. COMFORT ADJUSTMENTS

10. Reinstall the retaining clips from step 8.
11. Remove each screw from the trapeze bars and apply thread lock.
12. Reinstall each screw into the trapeze bars and tighten.
13. Reinstall the seat.
14. Reconnect the controller to the power base.
15. Reinstall the rear shroud.

Seat Position

You can move the seat forward or rearward by changing the extrusion mounting position.

To change the position:

1. Turn off the power to the controller.
2. Unplug the controller connector from the power base.
3. Remove the seat from the power base.
4. Remove both extrusions from the bottom of the seat.
5. Reposition the extrusions on a different set of mounting holes. You must move both extrusions the same number of holes either forward or rearwards. See figure 14.
6. Fasten the extrusions back onto the bottom of the seat.
7. Reinstall the seat.
8. Reconnect the controller.

Seatback Angle Adjustment

If your power chair is equipped with an adjustable seatback, you can adjust it to four (4) different angles: 90°, 102°, 105°, or 107°.

To adjust the seatback angle:

1. Remove the adjusting screws from each seat hinge. See figure 15.
2. Set the seatback at the desired angle.
3. Reinstall the adjusting screws to each seat hinge and tighten.

Reclining Seat

If your power chair is equipped with a reclining seat, you can adjust the seatback with the seatback release lever. The lever is located on the right side of the seat base. See figure 5.

To adjust the recline angle:

1. Push down on the seatback release lever.
2. Lean forward or rearwards to the desired position.
3. Release the lever.

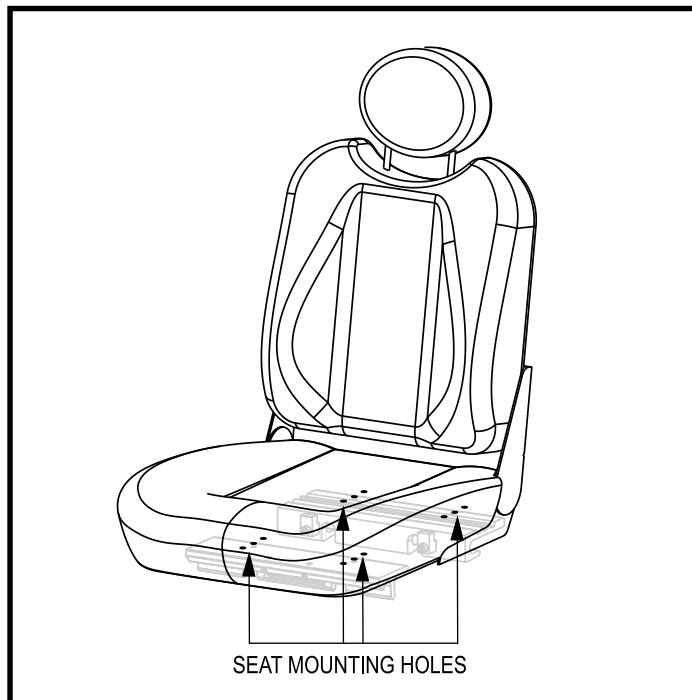

Figure 14. Seat Position Adjustment

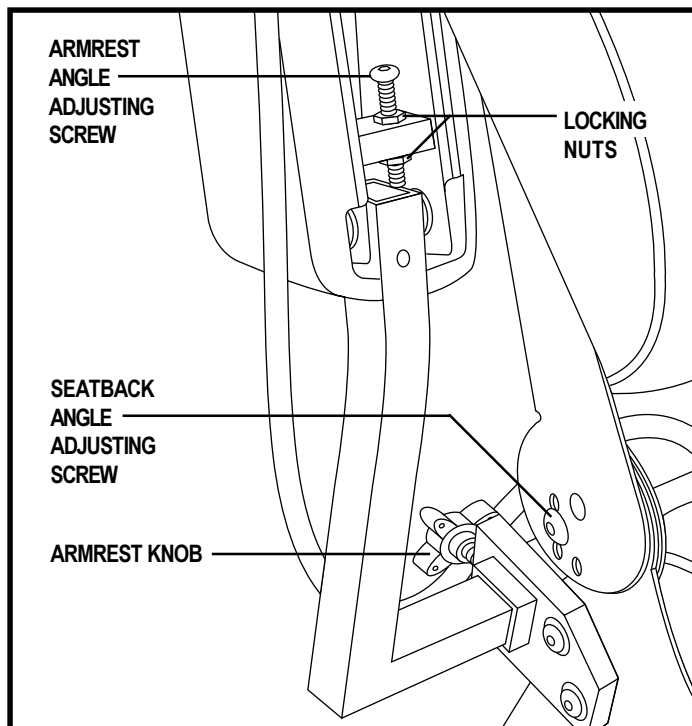

Figure 15. Seatback Angle Adjustment

V. COMFORT ADJUSTMENTS

Armrest Width Adjustment

You can change each armrest's width independently of the other.

NOTE: Changing the armrest width may increase the overall width of your power chair.

To change the armrest width:

1. Locate the two armrest knobs on each side of the armrest receiver bracket. See figure 15.
2. Loosen the knobs.
3. Slide the armrests in or out to the desired width.
4. Tighten the knobs.

Armrest Angle Adjustment

To change the armrest angle:

1. Lift the armrest straight up so that it is perpendicular to the floor. See figure 15.
2. Loosen the locking nuts.
3. Turn the adjusting screw clockwise to lower the front of the armrest, or turn the adjusting screw anticlockwise to raise the front of the armrest.
4. Tighten the locking nuts to lock the adjusting screw into place.

Foot Platform Height

The foot platform height is easily adjusted to different heights in 1.27 cm increments.

To raise or lower the foot platform:

1. Remove the quick release fasteners from the foot platform bracket. See figure 16.
2. Raise or lower the foot platform to the desired height.
3. Reinstall the quick release fasteners into the foot platform bracket and tighten.

Foot Platform Depth

To adjust the foot platform depth:

1. Remove the quick release fasteners from the foot platform bracket. See figure 16.
2. Move the foot platform in or out to the desired depth.
3. Reinstall the quick release fasteners into the foot platform bracket and tighten.

Quick Release Fasteners: The foot platform is attached to the power base with two quick release fasteners. See figure 16. Each quick release fastener consists of a bolt, a lever, and a nut. See figure 17. The lever has a cam on the end that allows it to clamp into place. The quick release fastener has two states: clamped and unclamped. When the lever is open, the quick release fastener is unclamped. When the lever is closed, the quick release fastener is clamped.

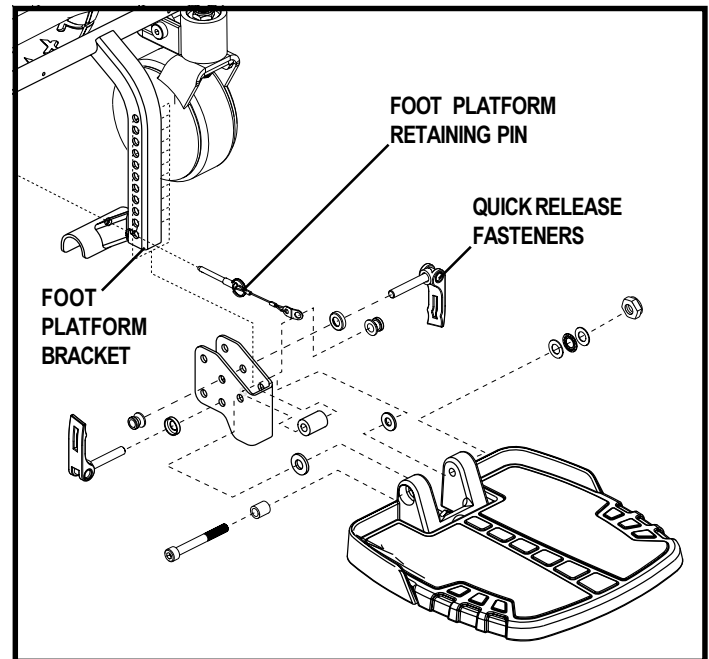

Figure 16. Foot Platform Adjustment

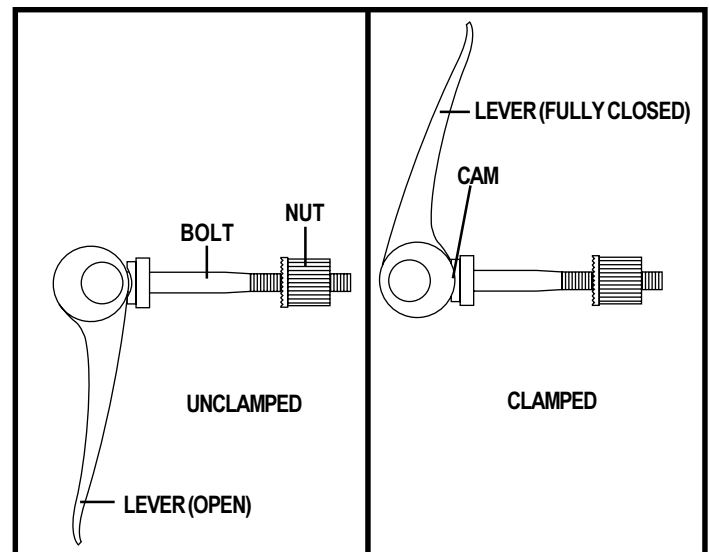

Figure 17. Quick Release Fastener Operation

V. COMFORT ADJUSTMENTS

To clamp the quick release fastener:

1. Make sure the lever is in the open position.
2. Turn the nut clockwise until it is snug.
3. Rotate the lever until it is in the fully closed position.

NOTE: *If the lever will not rotate to the fully closed position, then turn the nut anticlockwise one-quarter or one-half turn.*

Foot Platform Angle

You can adjust the angle of the foot platform with a hex key. See figure 16.

To adjust the foot platform angle:

1. Flip up the foot platform and locate the setscrew.
2. Turn the setscrew anticlockwise to raise the front of the foot platform.
3. Turn the setscrew clockwise to lower the front of the foot platform.

Controller Position

You can position the controller for either left-hand or right-hand use.



WARNING! Do not place the controller cable so that it can be pinched in the seat frame or the power base frame.

To change the controller position:

1. Turn the rear shroud fasteners one-quarter turn. See figure 6.
2. Remove the rear shroud.
3. Unplug the controller connector from the power base.
4. Cut the wire tie(s) securing the controller cable to the armrest.
5. Flip up the armrest and loosen the setscrew. See figure 18.
6. Slide the controller out of the armrest.
7. Loosen the setscrew in the other armrest.
8. Place the controller in the other armrest.
9. Tighten the setscrew to secure the controller.
10. Use a wire tie to secure the controller cable to the armrest.
11. Plug the controller connector into the power base.
12. Reinstall the rear shroud and tighten the fasteners.

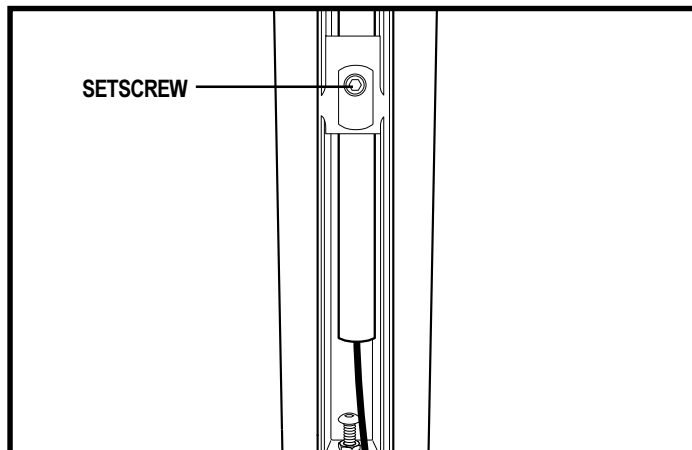

Figure 18. Underside of Armrest

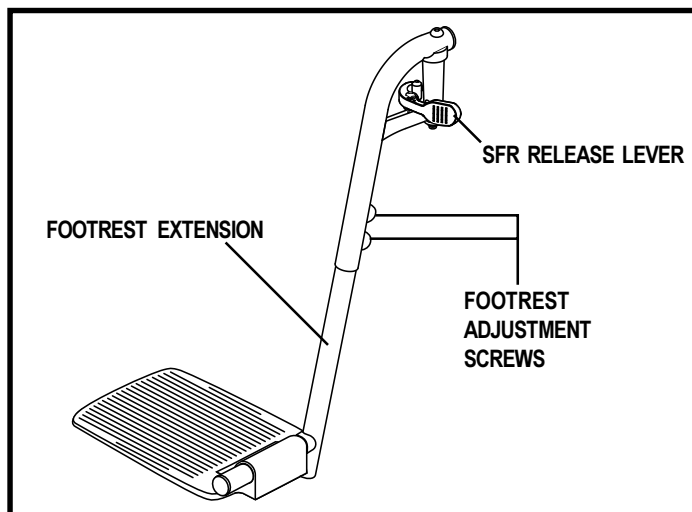

Figure 19. Swing-Away Footrests

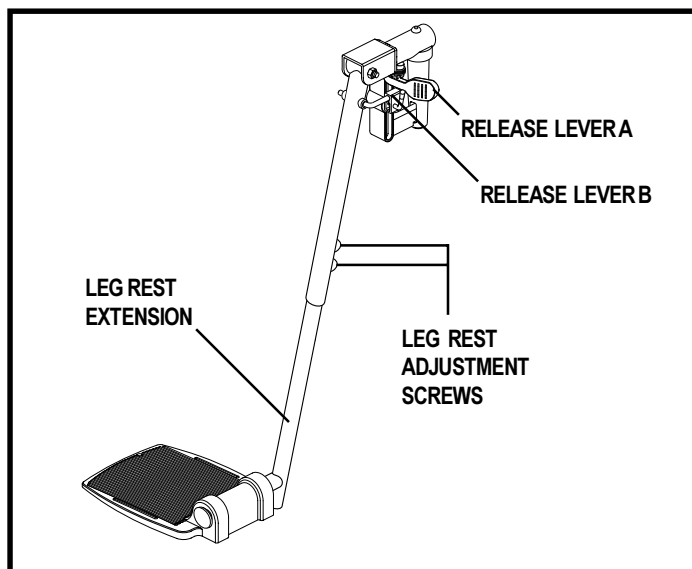

Figure 20. Elevating Leg Rests

V. COMFORT ADJUSTMENTS

Swing-away Footrests

Swing-away Footrests (SFRs) enable you to rotate the footrests to the side before you transfer onto or off of your power chair. See figure 19.

To rotate the SFRs:

1. Push in the release lever.
2. Rotate the SFRs.

To adjust the SFR length:

1. Remove the two adjustment screws from the side of each footrest extension.
2. Slide the footrest up or down to the desired length.
3. Reinstall the two adjustment screws.

Elevating Leg Rests (Optional)

Elevating Leg Rests (ELRs) offer an infinite range of adjustment for the leg angle and a footrest adjustment range of 30.5-48 cm. See figure 20.

To rotate the ELRs:

1. Push in release lever A.
2. Rotate the ELRs.

To adjust the ELR angle:

1. Push down release lever B.
2. Move the leg rest to the desired angle.

To adjust the ELR length:

1. Remove the two adjustment screws from the side of each leg rest extension.
2. Slide the leg rest up or down to the desired length.
3. Reinstall the two adjustment screws.

Heavy Duty Drop-in Leg Rests

You can adjust the forward/back position, as well as the length of the heavy duty drop-in leg rests. See figure 21.

To adjust the forward/back position:

1. Remove the adjustment bolts from the side rails.
2. Move the leg rest hanger in or out to the desired position.
3. Align the adjustment holes in the leg rest hanger with those in the side rail.
4. Reinstall the adjustment bolts to secure the leg rest hangers.

To adjust the leg rest length:

1. Remove the adjustment screws from the leg rest extension.
2. Slide the leg rest up or down to the desired length.
3. Align the adjustment holes in the leg rest extension and reinstall the adjustment screws.

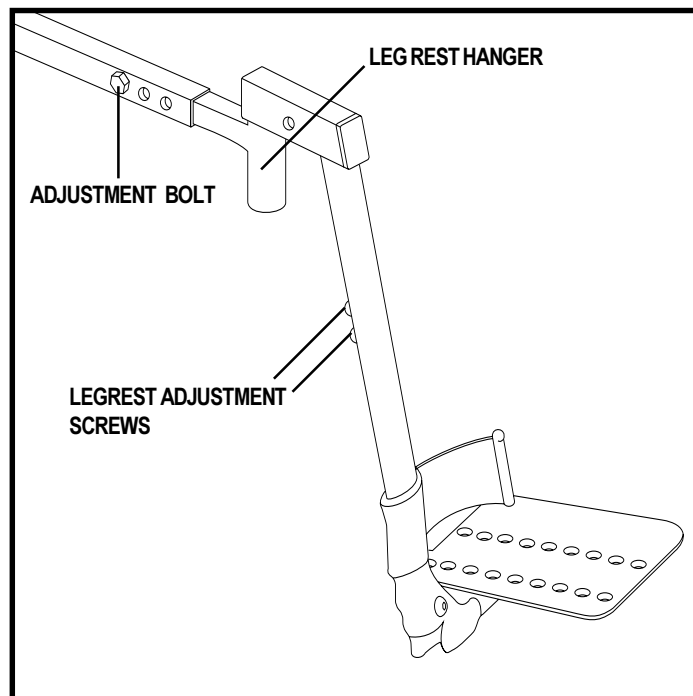

Figure 21. Heavy Duty Drop-In Leg Rests

V. COMFORT ADJUSTMENTS

MULTI-AXIS FOOT PLATE

The multi-axis foot plate assembly can be installed on either a swing-away footrest or an elevating leg rest. The multi-axis foot plate has four adjustments: leg rest length (A), position (B), tilt (C), and angle (D). See figure 22.

To change leg rest length (A):

1. Remove the hardware.
2. Move the leg rest to the desired position.
3. Reinstall the hardware.

To change foot plate position (B):

1. Remove the hardware.
2. Move the foot plate to the desired position.
3. Reinstall the hardware.

To change foot plate tilt (C):

1. Loosen the hardware.
2. Tilt the foot plate to the desired position.
3. Tighten the hardware.

To change foot plate angle (D):

1. Turn the setscrew clockwise to decrease the angle.
2. Turn the setscrew anticlockwise to increase the angle.

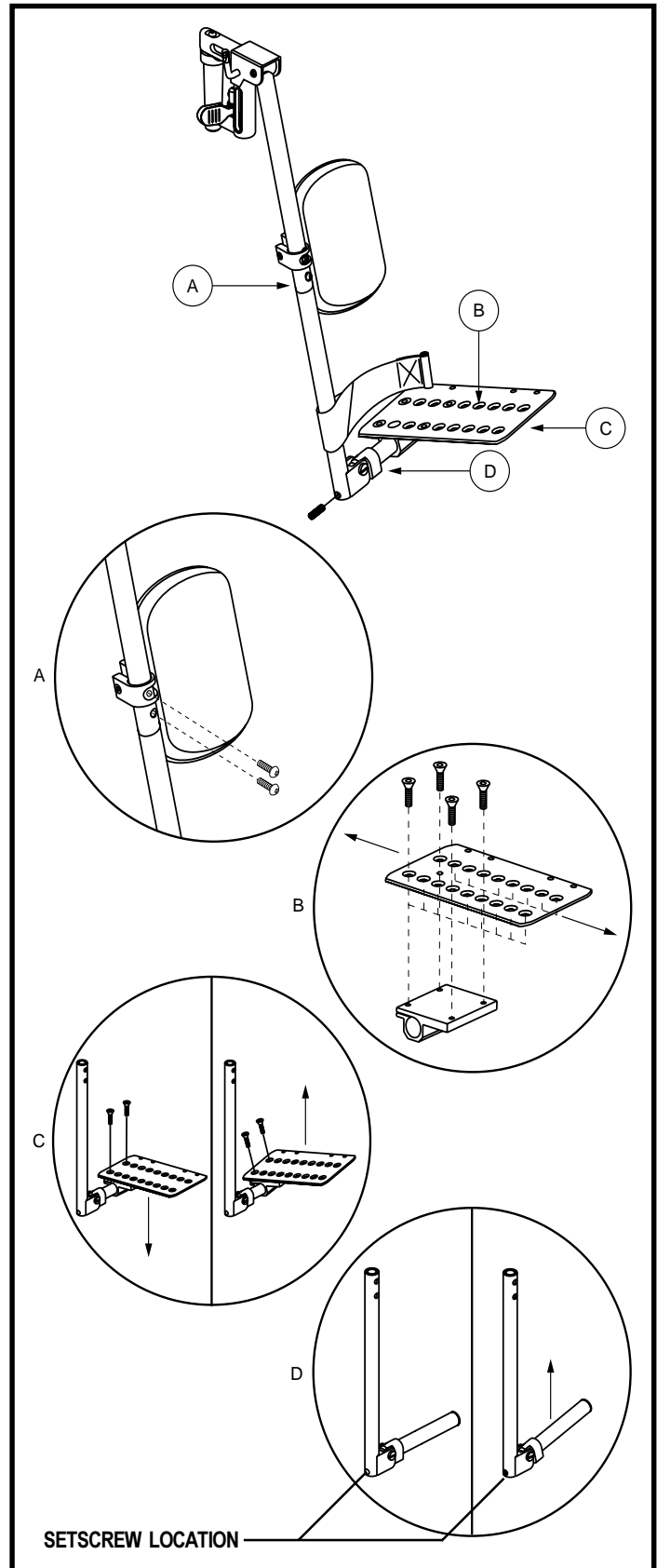

Figure 22. Multi-Axis Foot Plate (ELR Shown)

VI. BATTERIES AND CHARGING

BATTERIES AND CHARGING

The Jazzy 600 uses two long-lasting, 12-volt, deep-cycle batteries. These batteries are sealed and maintenance free. Since they are sealed, there is no need to check the electrolyte (fluid) level. Deep-cycle batteries are designed to handle a longer and deeper discharge. Though they are similar in appearance to automotive batteries, they are not interchangeable. Automotive batteries are not designed to handle a long, deep discharge, and also are unsafe for use in power chairs.



WARNING! Battery posts, terminals, and related accessories contain lead and lead compounds. Wash hands after handling.

Charging the Batteries

The battery charger is essential in providing long life for your power chair batteries. It is designed to optimize your power chair's performance by charging the batteries safely, quickly, and easily.



WARNING! You must recharge your power chair's batteries with the supplied off-board battery charger. Do not use an automotive-type battery charger.



PROHIBITED! Removal of grounding prong can create electrical hazard. If necessary, properly install an approved 3-pronged adapter to an electrical outlet having 2-pronged plug access. Failure to heed could result in personal injury and/or property damage.



PROHIBITED! Never use an extension lead to plug in your battery charger. Plug the charger directly into a properly wired standard wall outlet.

To charge the batteries using the off-board charger:

1. Position your power chair next to a standard wall outlet.
2. Be certain the controller power is turned off.
3. Plug the off-board charger into the off-board charger/programming socket on the controller. See VII. "Operation."
4. Plug the off-board charger into the wall outlet.
5. If it is a Pride off-board charger, then there are two lights in it. The red light indicates that power to the off-board charger is on. The green light indicates that the batteries are fully charged. If it is not a Pride off-board charger, then follow the instructions supplied by the manufacturer.
6. When the batteries are fully charged, unplug the off-board charger from the wall outlet and then from the controller.

Battery Break-in

To break in new batteries for maximum efficiency:

1. Fully recharge any new battery prior to its initial use. This brings the battery up to about 90% of its peak performance level.
2. Operate your power chair throughout the house and grounds. Move slowly at first, and don't stray too far until you become accustomed to the controls and break in the batteries.
3. Give the batteries another full charge of 8 to 14 hours and operate your power chair again. The batteries will now perform at over 90% of their potential.
4. After four or five charging cycles, the batteries will top off at 100% charge and last for an extended period.

Frequently Asked Questions (FAQs)

How does the charger work?

The battery charger takes the standard wall outlet voltage (alternating current) and converts it to 24 VDC (direct current). The power chair batteries use direct current to run your power chair. When the battery voltage is low, the charger works harder to charge the battery. As the battery voltage approaches full charge, the charger doesn't work as hard to complete the charging cycle. When the batteries are fully charged, the amperage from the charger is nearly at zero. This is how the charger maintains a charge but does not overcharge the battery.

VI. BATTERIES AND CHARGING

Can I use a different battery charger?

You should use the charger supplied with the power chair. It is the safest, most efficient tool to charge the batteries. We do not recommend using other types of chargers (e.g., an automotive battery charger).

NOTE: *Your power chair's charger will not operate after the batteries have been discharged to nearly zero voltage. If this happens, call your authorised Pride Provider for assistance.*

How often must I charge the batteries?

Many factors come into play when deciding how often to charge the batteries. You may use your power chair all day on a daily basis or you may not use it for weeks at a time.

■ Daily Use

If you use your power chair on a daily basis, charge the batteries as soon as you are finished using your power chair. Your power chair will be ready each morning to give you a full day's service. It is recommended that you charge the batteries 8 to 14 hours after daily use.

■ Infrequent Use

If you use your power chair infrequently (once a week or less), you should charge the batteries at least once per week for 12 to 14 hours.

NOTE: *Keep your batteries fully charged and avoid deeply discharging your batteries. Do not charge the batteries for more than 24 hours at a charging cycle.*

How can I get maximum range or distance per charge?

Rarely do you have an ideal driving situation such as smooth, flat, hard terrain with no wind, hills, or curves. More often you are presented with hills, pavement cracks, uneven and loosely packed surfaces, curves, and wind. All of these factors will affect the distance or running time per battery charge. Below are a few suggestions for obtaining the maximum range per charge:

- Always charge the batteries fully prior to your trip.
- Plan your trip in advance to avoid inclines if possible.
- Limit baggage weight to essential items.
- Try to maintain an even speed and avoid stop-and-go driving.

What type of batteries should I use?

We recommend deep-cycle batteries that are sealed and maintenance free. Both AGM and Gel-Cell are deep-cycle batteries that are similar in performance. Refer to the Specifications Table for more information regarding the batteries used with your power chair.



WARNING! Corrosive chemicals contained in batteries. Use only AGM or Gel-Cell batteries to reduce the risk of leakage or explosive conditions.

Why do my new batteries seem weak?

Deep-cycle batteries employ a much different chemical technology than that used in car batteries, nickel-cadmium (nicads), or in other common battery types. Deep-cycle batteries are specifically designed to provide power, drain down their charge, and then accept a relatively quick recharge. AGM and Gel-Cell batteries should be charged as often as possible. They do not have a "memory" like nickel-cadmium batteries.

VI. BATTERIES AND CHARGING

We work closely with our battery manufacturer to provide a battery that best suits your power chair's specific demands. Fresh batteries arrive regularly at Pride and are promptly shipped with a full charge. During shipping, the batteries encounter temperature extremes that may influence initial performance. Heat robs the charge from the battery, and cold slows the power available and extends the time needed to recharge the battery (just as with a car battery).

It might take a few days for the temperature of the battery to stabilize and adjust to its new ambient temperature. More importantly, it will take a few "charging cycles" (a partial drain— then a full recharge) to establish the critical chemical balance that is essential to the battery's peak performance and long life. It will be well worth it to take the time to break in your battery properly.

***NOTE:** The useful life of a battery is quite often a reflection of the care it receives.*

How can I ensure maximum battery life?

A fully charged deep-cycle battery will provide reliable performance and extended battery life. Keep your power chair's batteries fully charged whenever possible. Batteries that are regularly and deeply discharged, infrequently charged, or stored without a full charge may be permanently damaged, causing unreliable power chair operation and limited battery life.

How should I store my power chair and its batteries?

If you do not use your power chair regularly, we recommend maintaining battery vitality by charging the batteries at least once per week.

If you do not plan on using your power chair for an extended period, fully charge the batteries prior to storage. Disconnect the battery harnesses and store the power chair in a warm, dry environment. Avoid temperature extremes, such as freezing and excessively hot conditions, and never attempt to charge a frozen battery. A cold or frozen battery should be warmed for several days prior to recharging.

What about public transportation?

AGM and Gel-Cell batteries are designed for application in power chairs and other mobility vehicles. These batteries are Federal Aviation Administration (FAA) approved, allowing safe transportation on aircraft, buses, and trains, as there is no danger of spillage or leakage. We suggest you contact the carrier's ticket counter in advance to determine that carrier's specific requirements.

What about shipping?

If you wish to use a freight company to ship your power chair to your final destination, repack your power chair in the original shipping container and ship the batteries in separate boxes.

VII. OPERATION

FLIGHT CONTROLLER

The electronic controller is what you use to operate your power chair. It takes the battery voltage and sends it to the appropriate system. The electronic controller enables you to move the power chair, as well as monitor battery charge, electronic controller functions, and the condition of your electrical system. The FLIGHT is part of a modular electronic controller system. The system consists of more than one module. Typically, the FLIGHT is mounted to one of the armrests. See figure 22. It is connected to a power module located on the power base through the controller communications cable. The FLIGHT may be used to control some optional systems, such as lights.

The controller supplied with your power chair has been pre-programmed to meet the needs of the end user. The program is set using either a personal computer with software provided by the controller manufacturer or with a hand-held programmer, also provided by the controller manufacturer.



WARNING! The controller program can affect speed, acceleration, deceleration, and braking. But if it is programmed incorrectly or outside of the safe limits as determined by your healthcare professional, it can create a dangerous situation. Only the power chair manufacturer, an authorised representative of the manufacturer, or a trained service technician should program the controller.

The FLIGHT consists of:

1. joystick
2. keypad
3. off-board charger/programming socket
4. controller connector
5. controller power module

Joystick

The joystick controls the direction and speed of your power chair. When you move the joystick from the neutral (centre) position, the electromagnetic brakes release and allow your power chair to move. The farther you push the joystick from its neutral position, the faster your power chair moves. When you release the joystick and allow it to return to the neutral position, you engage the electromagnetic brakes. This causes your power chair to decelerate and come to a complete stop.



WARNING! If your power chair begins to move in an unexpected manner, immediately release the joystick. Unless the joystick is damaged, this action should stop your power chair.

Keypad

The keypad is located in front of the joystick. It contains keys necessary to operate your power chair. See figure 24.

Horn Key

The horn key activates the horn.

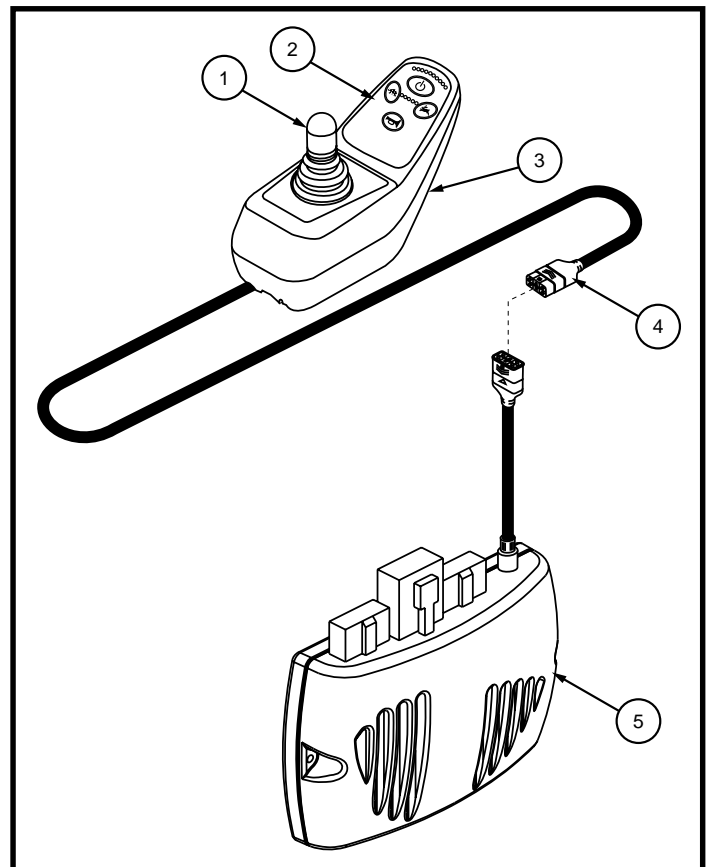

Figure 23. FLIGHT Controller

VII. OPERATION

On/Off Key

The on/off key turns the FLIGHT on and off.



WARNING! Unless faced with an emergency situation, do not use the on/off key to stop the chair. This will cause the power chair to stop abruptly.

WARNING! Always turn the power off when you are stationary to prevent unexpected movement.

Battery Condition Meter

The battery condition meter consists of ten lights arranged in an arc over the on/off key. As the battery voltage drops, the number of lights reduces from right to left. When the battery capacity drops to 10% or below, the left red LED will flash.

- **Left Red LED Flashing:** Battery charge is low; Charge the batteries as soon as possible.
- **Right-to-Left Ripple of LEDs:** FLIGHT is in lock mode; Unlock the FLIGHT.
- **Left-to-Right Ripple of LEDs Alternating with Steady Display:** FLIGHT is in programming, inhibit, or charging mode.
- **Right Green LED Flashing:** FLIGHT is in speed limit mode.
- **All LEDs Flashing Slowly:** The joystick was not in the neutral position when the controller was turned on. If you get “all LEDs flashing slowly,” turn off the controller, allow the joystick to return to the neutral position, then turn on the controller.
- **All LEDs Flashing Quickly:** The FLIGHT has detected a fault; Refer to the Error Code table.

Lock Mode

The Flight controller is equipped with a feature that enables you to “lockout” unauthorised users.

To lock the FLIGHT controller:

1. While the power is on, press and hold the on/off key for 2 seconds. The display will turn off immediately. After 2 seconds, all LEDs will flash briefly and the horn will sound a short beep.
2. The FLIGHT controller is now locked.

To unlock the FLIGHT controller:

1. While the FLIGHT is locked, press the on/off key to turn on the FLIGHT. All LEDs will flash briefly. The LEDs will then slowly ripple from right to left.
2. Press the Horn Key twice before the LED ripple has completed, approximately 10 seconds. The FLIGHT is now unlocked.

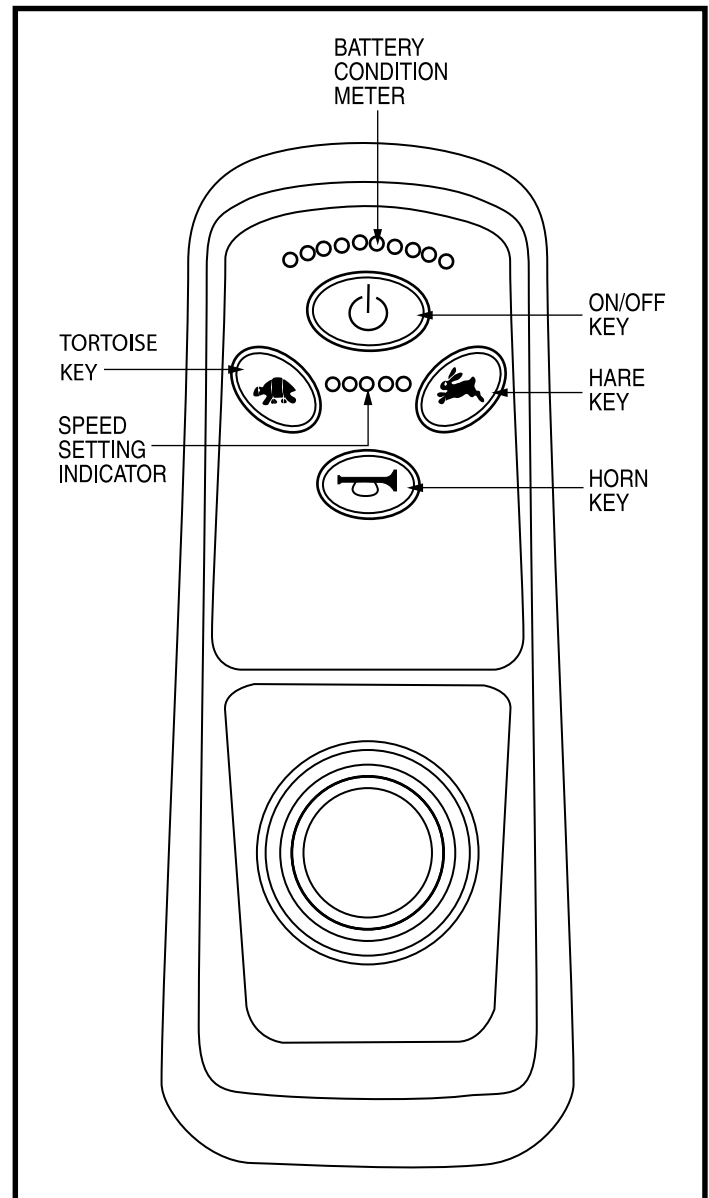

Figure 24. FLIGHT Controller Keypad

VII. OPERATION

Speed Keys

There are two keys that control the speed. Press the hare key to increase the speed. Press the tortoise key to decrease the speed. The speed setting is displayed on the speed indicator. If your power chair was programmed with a drive profile, contact your authorised Pride Provider for more information.

NOTE: *We recommend that the first few times you operate your power chair, you set the speed to the slowest setting until you become familiar with your new power chair.*

Off-board Charger/Programming Socket

You may use an off-board charger to charge the power chair batteries through the 3-pin socket located on the front of the FLIGHT. If you use an off-board charger, the charger current should not exceed 8 amps. Contact your authorised Pride Provider for more information.



WARNING! Only chargers with Neutrik NC3MX plugs should be connected to the off-board charger/programming socket. See your authorised Pride Provider for more information.

NOTE: *The socket may also be used for reprogramming the FLIGHT. Contact your authorised Pride Provider for more information.*

Sleep Mode (If Enabled)

The power chair controller features a sleep mode. Sleep mode is a built-in circuit that will automatically shut off the main power if the joystick is not moved in any direction for a period of time. This time factor is programmed into the controller. To restore power and continue, push and key on the keypad.

Error Codes

The battery condition meter will flash error codes when the FLIGHT controller detects an abnormal condition in the electrical system. All of the battery condition meter LEDs will flash a number of times quickly, then pause, then flash again. The battery condition meter will continue to flash the error codes until the problem is fixed. The table below identifies the individual error codes. If any of these error codes persist, contact your authorised Pride Provider.

Error Sequence	Diagnosis	Solution
•—•—•—	FLIGHT Module Fault	See your authorised Pride Provider.
••—••—•—	FLIGHT Accessory Fault	See your authorised Pride Provider.
•••—•••—	Left Motor (or connection) Fault	Check left motor wiring.
••••—••••—	Right Motor (or connection) Fault	Check right motor wiring.
•••••—•••••—	Left Park Brake Fault	Check motor/brake wiring.
••••••—••••••—	Right Park Brake Fault	Check motor/brake wiring.
•••••••—•••••••—	Low Battery Fault	Check that the battery wiring is secure.
••••••••—••••••••—	Over-voltage Fault	Check that the battery wiring is secure.
•••••••••—•••••••••—	CANL Fault	See your authorised Pride Provider.
••••••••••—••••••~	CANA Fault	See your authorised Pride Provider.
•••••••••••—••••••~	Stall Timeout	Turn unit off, then on.
••••••~••••••~	Module Mismatch	See your authorised Pride Provider.

VIII. CARE AND MAINTENANCE

CARE AND MAINTENANCE

Your Jazzy 600 is a sophisticated power chair. Like any motorized vehicle, it requires routine maintenance checks. You can perform some of these checks, but others require assistance from your authorised Pride Provider. Preventive maintenance is very important. If you follow the maintenance checks in this section as scheduled, you can help ensure that your power chair gives you years of trouble-free operation. If you have any doubt as to your power chair's care or operation, contact your authorised Pride Provider.



WARNING! Prevent injury. Do not service the power chair when the seat is occupied.

Your power chair, like most electrical equipment, is susceptible to damage from the elements. Avoid damp areas of any kind.



WARNING! Direct exposure to water or dampness could cause the power chair to malfunction electronically and mechanically. Water can cause electrical components to corrode and the chair's frame to rust.

Should your power chair come in contact with water:

1. Dry your power chair as thoroughly as possible with a towel.
2. Allow your power chair to sit in a warm, dry place for 12 hours to allow unseen water to evaporate.
3. Check the joystick operation and the brakes before using your power chair again.
4. If any inconsistencies are found, take your power chair to your authorised Pride Provider.

Temperature

- Some of the parts of your power chair are susceptible to extreme changes in temperature. Always keep your power chair between the temperatures of -7°C and 50°C .
- In extremely cold temperatures the batteries may freeze. The specific temperature at which they freeze depends on a number of factors, such as battery charge, usage, and composition of the batteries (e.g., AGM or Gel-Cell).
- Temperatures above 50°C may cause your power chair to operate at a reduced speed. This reduced speed is a safety feature built into the controller that helps prevent damage to the motor and other electrical components. See VII. "Operation."

General Guidelines

- Avoid knocking or bumping the controller, especially the joystick.
- Avoid prolonged exposure of your power chair to extreme conditions, such as heat, cold, or moisture.
- Keep the controller clean.
- Check all connectors to ensure that they are all tight and secured properly.
- Make sure pneumatic drive tyres are inflated to **2.4 bar**.



WARNING! Overinflating tyres can cause them to explode and can result in personal injury.

WARNING! Do not use a high pressure hose to inflate your tyres.

- Use a rubber conditioner on the tyre sidewalls to help preserve them.



WARNING! Never use a rubber conditioner on the tread area of the tyres; doing so may make the tyres slippery and cause your power chair to skid.

VIII. CARE AND MAINTENANCE

- The body shroud has been sprayed with a clear sealant coating. You can apply a light coat of car wax to help it retain its high-gloss appearance.
- Check all electrical connections. Make sure they are tight and are not corroded. Batteries must sit flat within the battery tray, with the battery terminals facing inward, toward each other. Refer to the battery wiring label for the correct wiring layout.
- All wheel bearings are prelubricated and sealed. They require no subsequent lubrication.

Daily Checks

- With the controller turned off, check the joystick. Make sure it is not bent or damaged and that it returns to the neutral position when you release it. Check the rubber boot around the base of the joystick for damage. Visually inspect the boot. Do not handle or try to repair it. See your authorised Pride Provider if there is a problem.
- Visually inspect the controller cable. Make sure that it is not frayed, cut, or has any wires exposed. See your authorised Pride Provider if there is a problem.
- Check for flat spots on solid tyres. Flat spots could adversely affect stability.

Weekly Checks

- Disconnect and inspect the controller from the power base. Look for corrosion. Contact your authorised Pride Provider if necessary.
- Ensure that all parts of the controller system are securely fastened to your power chair. Do not overtighten any screws.
- Check for proper tyre inflation. There should be **2.4 bar** in each pneumatic tyre. If a tyre does not hold air, see an authorised Pride Provider for replacement of the tube.
- Calibrate the joystick if a noticeable difference in performance is detected or if the joystick does not operate properly. To calibrate the joystick, power off the unit, place the joystick in the neutral position, and power the unit back on. If a problem still exists with your joystick's performance, contact your authorised Pride Provider.
- Check the brakes. This test should be carried out on a level surface with at least 1 meter of clearance around your power chair.

To check the brakes:

1. Turn on the controller and turn down the speed level of your power chair.
2. After one second, check the battery condition meter. Make sure that it remains on.
3. Slowly push the joystick forward until you hear the electric brakes click. Immediately release the joystick. You must be able to hear each electrical brake operating within a few seconds of joystick movement. Repeat this test three times, pushing the joystick rearwards, then left, and then right.

Monthly Checks

- Check for drive tyre wear. See your authorised Pride Provider for repair.
- Check the caster wheels for wear. Replace them as necessary.
- Check the caster forks for damage or fluttering which indicates that they may need to be adjusted or have the bearings replaced. See your authorised Pride Provider for repair.
- Keep your power chair clean and free of foreign material, such as mud, dirt, hair, food, drink, etc.

Yearly Checks

Take your power chair to your authorised Pride Provider for yearly maintenance. This helps ensure that your power chair is functioning properly and helps prevent future complications.

VIII. CARE AND MAINTENANCE

Storage

Your power chair should be stored in a dry place, free from temperature extremes. When storing, disconnect the batteries from the power chair. See VI. "Batteries and Charging."



WARNING! If you fail to store the unit properly, the frame can rust and the electronics can be damaged.

Cleaning Instructions



WARNING! Never hose off your power chair or place it in direct contact with water. Your power chair has a painted, ABS plastic body shroud that allows it to be easily wiped clean with a damp cloth.

WARNING! Never use any chemicals to clean a vinyl seat, as they may cause the seat to become slippery or dry out and crack. Use soapy water and dry the seat thoroughly.

Tyre/Wheel Replacement

If you have pneumatic tyres and you have a flat tyre, you can replace the tube. If your chair is equipped with a solid tyre insert, then you must replace the whole wheel assembly. Replacement tyres, tubes, and wheel assemblies are readily available through your authorised Pride Provider.



WARNING! To avoid possible injury, be sure that the controller's power is turned off and the power chair is not in freewheel mode before performing this procedure.

WARNING! Completely deflate the tyre before attempting repair.

Follow these easy steps for a quick and safe repair for both pneumatic and solid tyres:

1. Turn off the power to the controller.
2. Set the power chair on blocks.
3. If you are changing a pneumatic tyre, completely deflate it before removing the wheel.
4. Remove the drive wheel nut from the wheel hub.
5. Pull the wheel off the axle.
6. Remove the screws that fasten the two rim halves together. See figure 25.
7. Remove the old tube from the pneumatic tyre and replace it with a new tube or replace the entire assembly if it is a solid tyre.
8. Screw together the two rim halves.
9. Slide the wheel back onto the shaft. Make sure that the key is in the axle slot.
10. Reinstall the drive wheel nut onto the wheel hub and tighten.
11. Inflate the pneumatic tyre to **2.4 bar**.
12. Remove the power chair from the blocks.

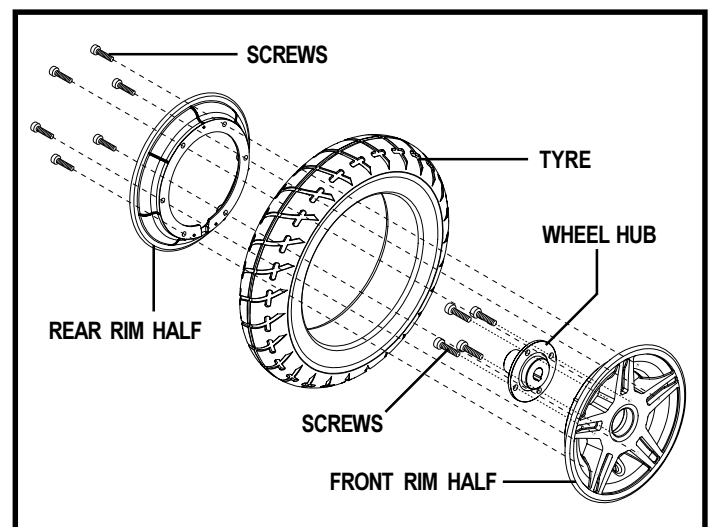

Figure 25. Jazzy 600 Drive Wheel

VIII. CARE AND MAINTENANCE

Battery Replacement

A battery wiring diagram is printed on a decal located on the front battery tray. See VI. “Batteries and Charging” for correct battery specifications.

WARNING! Prevent injury. Do not replace battery when seat is occupied.



WARNING! Battery posts, terminals, and related accessories contain lead and lead compounds. Wear goggles and gloves when handling batteries and wash hands after handling.

WARNING! Power chair batteries are heavy. See specifications table. If you are unable to lift that much weight, be sure to get help. Lifting beyond your capacity can result in personal injury.

To replace the batteries:

1. Turn off power to the controller.
2. Make sure that the power chair is in drive mode. See III. “Your Power Chair.”
3. Turn the rear shroud fasteners one-quarter turn in any direction. See figure 26.
4. Remove the rear shroud.
5. Disconnect the battery harness from the rear battery.
6. Remove the retaining pin and lift off the front cover using the foot platform bracket. See figure 16.
7. Slide the battery tray forward.
8. Disconnect the battery harness from the front battery.
9. Undo the hook and loop straps from both batteries.
10. Remove the batteries.
11. Replace with new batteries.
12. Fasten the hook and loop straps around both batteries.
13. Connect the battery harness to the front battery according to the battery wiring diagram. See figure 29.



WARNING! Prevent injury. Make sure you tighten the fasteners so that the connections are secure.

14. Slide the battery tray back into the power base.
15. Connect the battery harness to the rear battery.
16. Reinstall the front cover.
17. Reinstall the rear shroud.
18. Charge the batteries. See VI. “Batteries and Charging.”

VIII. CARE AND MAINTENANCE

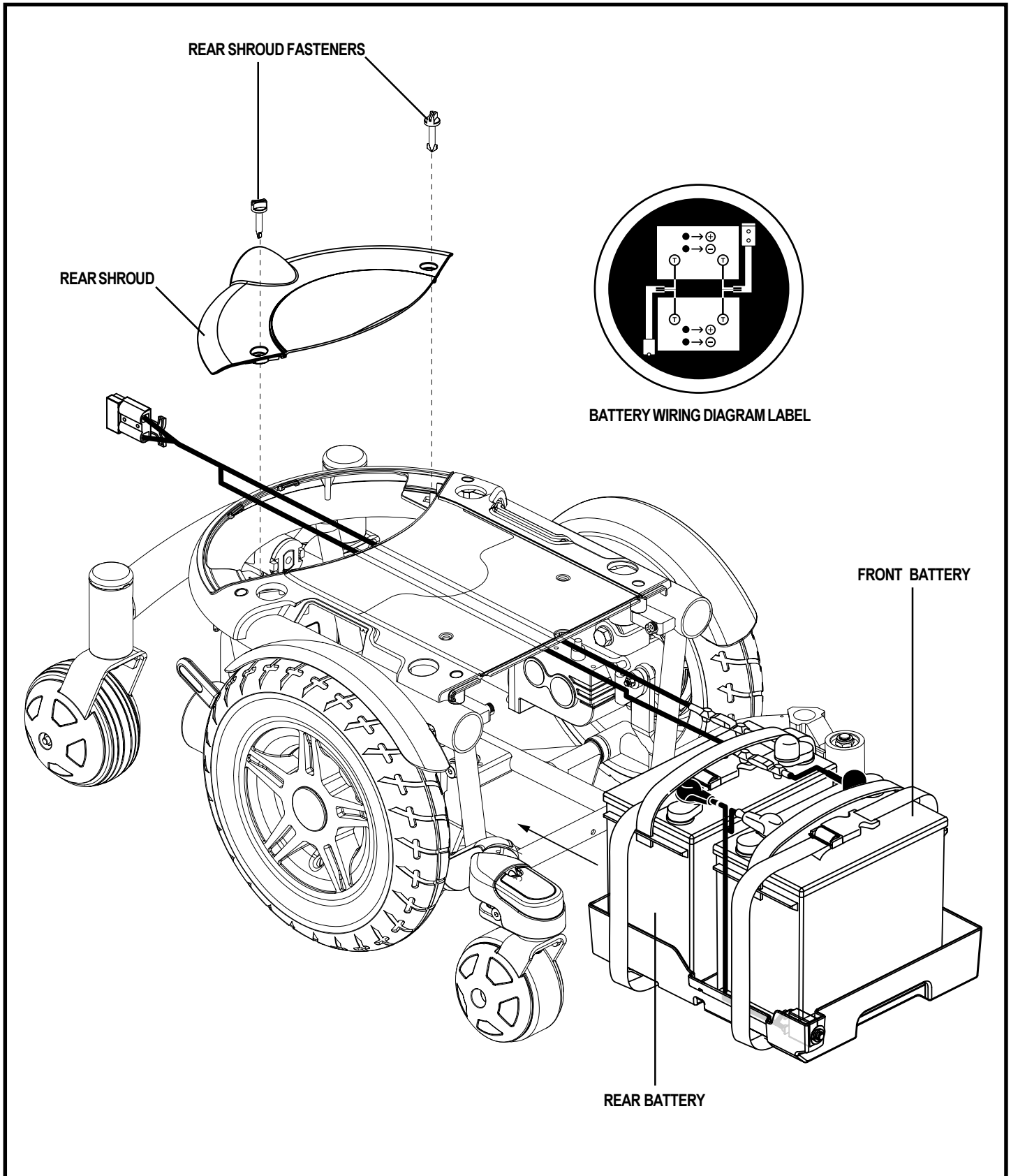

Figure 26. Battery Installation

VIII. CARE AND MAINTENANCE

When to See Your Authorised Pride Provider for Service

The following symptoms could indicate a serious problem with your power chair. If necessary, contact your authorised Pride Provider. When calling, have the model number, serial number, nature of the problem, and the error code if available.

- Motor noise
- Frayed harnesses
- Cracked or broken connectors
- Uneven wear on any of the tyres
- Jerky motion
- Pulling to one side
- Bent or broken wheel assemblies
- Does not power up
- Powers up, but does not move

Corrective Maintenance

If the battery condition meter does not light up when you turn on the power:

- Check the harness connections. Make sure they are tight.
- Check the circuit breaker. Reset it if necessary.
- Check the battery connections.

If the above conditions prove normal, you can load test the batteries with a battery load tester. These testers are available at automotive parts stores. Disconnect both batteries before load testing and follow the directions that come with the load tester. If either one of the batteries fails the load test, replace both of them. If your power chair still does not power up, contact your authorised Pride Provider.

I X . W A R R A N T Y

LIFETIME LIMITED WARRANTY

Structural frame components, including: platform, fork, seat post, and frame welds.

TWO-YEAR LIMITED WARRANTY

Drivetrain, including: differential, motor, and brake.

ONE-YEAR LIMITED WARRANTY

Your Pride Power Chair is fully guaranteed for twelve (12) months from the date of purchase against faults arising due to defects in manufacture or materials. This warranty does not detract from, but is in addition to your legal rights.

All electronic parts, including controllers and battery chargers, have a one (1) year warranty. Servicing to the controller or battery charger must be carried out by your authorised Pride Provider. Any attempt to open or dismantle these items renders the guarantee void on that item.

NOT COVERED UNDER WARRANTY

This guarantee does not extend to those items which may need replacement due to normal wear and tear (tyres, belts, bulbs, upholstery, plastic shrouds, motor brushes, fuses, and batteries), or damage to the product caused by misuse or accident for which Pride or its agent cannot be held responsible. This warranty does not include labour or service calls.

Batteries

Batteries are covered by a twelve (12) month warranty from the original manufacturer.

Gradual deterioration in performance due to being left in a discharged state, left in cold conditions for long periods of time, or worn out through heavy use is not covered.

SERVICE CHECKS AND WARRANTY SERVICE

Warranty service can be performed by your authorised Pride Provider. Please contact your authorised Pride Provider for advice on the current cost affecting the service visit.

REPLACEMENT UNITS

The availability of replacement units is subject to the discretion of the provider, not the manufacturer. For more information regarding replacement units, contact your authorised Pride Provider.

NOTES

NOTES

NOTES

Jazzy Power Chairs®

How a Power Chair Should Feel™



Quality Control - Jazzy 600

Thank you for making the Jazzy 600 your choice in power chairs.

We have thoroughly inspected your power chair. The following checkmarks indicate that it has been test driven and inspected.



Pride keeps a more detailed report on file at the factory.

Date Inspected

Model Number

Inspector

Serial Number