



**drive**  
MEDICAL DESIGN & MANUFACTURING

US Drive Medical, NY 11050  
UK Drive Medical Ltd, HX5 9JP  
DE Drive Medical GmbH & Co. KG, D-88316 Isny

© 2011 Medical Depot, Inc. All Rights Reserved  
Drive is a trademark of Medical Depot Inc  
Port Washington, New York NY 11050  
Made in China



enigma xs2  
aluminium wheelchair



US [www.drivemedical.com](http://www.drivemedical.com)  
UK [www.drivemedical.co.uk](http://www.drivemedical.co.uk)  
DE [www.drivemedical.de](http://www.drivemedical.de)

**drive**  
MEDICAL DESIGN & MANUFACTURING

## contents

1. Contents
2. Introduction
3. Parts Description
4. Adjustment Features
  - i. Rear Wheels
  - ii. Upholstery Tension
  - iii. Brake Adjustments
  - iv. Leg Rest Adjustment
  - v. Arm Rest Position
5. Folding Back Mechanism
6. Disassembly and Folding
7. Using the Stepper Tube
8. Installing a Powerpack
9. Specification
10. Warranty
11. Use as Seat In a Motor Vehicle

## introduction

This Enigma XS2 wheelchair is designed for occasional or frequent use, and can be used indoors and outdoors. The wheelchair is designed for a single user of up to 135kg (21 stone). The frame can accommodate either 24" self propel wheels or 12.5" transit wheels.

The wheelchair can be manually moved in forward and reverse and is propelled either by the wheelchair user or a carer, depending upon the model of wheelchair in use.

## parts description



## adjustment features

A number of adjustments may be made to the wheelchair to suit a user's individual requirements:

- i. **Rear Wheels.** Use the axle bracket to alter the vertical or horizontal position of the 24" self-propel wheel, or the horizontal position of the 12". Remove the two screws and nyloc nuts and reposition as required. Reattach the fasteners and alter the brakes as required. We recommend this is adjusted by your Drive Medical dealer.
- ii. **Upholstery.** This wheelchair features a tension adjustable back canvas. To adjust the tension, first remove the cushion and then adjust the Velcro straps. Ensure the straps are not too taut as this can damage the wheelchair.
- iii. **Brake Adjustment.** Adjustment is made to the brake by loosening the Allen key bolt heads and by sliding the brake unit along the frame. The brakes will have to be readjusted if the rear wheel position has been altered. We recommend this is adjusted by your Drive Medical dealer.
- iv. **Leg Rest Adjustment.** The leg rest height and footplate angle can be adjusted. To alter the leg rest height, remove the Allen head bolt and nyloc nut. Reposition as required, and then resecure fasteners. To alter the footplate angle, loosen the allen head bolt on the plastic footplate. Reposition as required then retighten bolt.
- v. **Adjusting the Arm Pad Position.** Press the silver button on the arm pad and push the arm pad forwards and backwards to the required position.
- vi. **Adjusting the Anti-Tip Wheels.** See the Using a Stepper Tube section.

## folding back mechanism

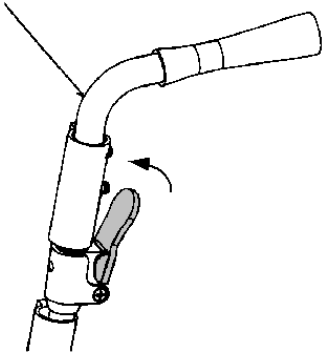

Push the black paddle (arrowed) towards the back post with your thumb whilst pulling the handle down. Repeat this operation for the other handle. To put the backrest back into position, lift both handles together and the folding mechanism will lock back automatically.

Do not push down on the handles to raise the front of the wheelchair, as this could result in damage to the wheelchair. Use the stepper tube as described later in the handbook.

## disassembly and storage

This wheelchair has a number of quick release components and the wheelchair frame is easily foldable to facilitate a light carry weight and minimize storage space.

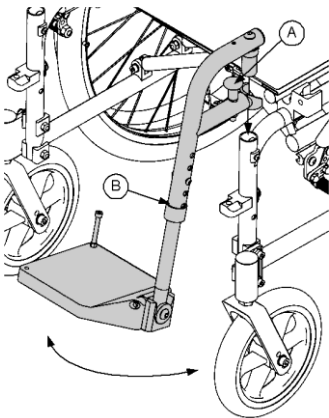

### 1. Leg Rests

Leg rests will swing in or out to reduce the length of the wheelchair. Pull lever "A" whilst rotating the leg rest "B".

To remove, swing out the leg rest approximately 45° and pull up on the leg rest.

Please note on some models the lever "A" is replaced with a looped handle. In this case, pull the looped handle.

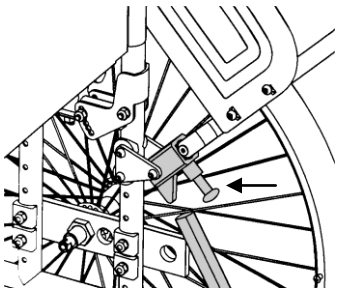

## 2. Armrests

Press the lever at the front of the armrests to release the front of the armrest. The armrest can now be flipped up.

To remove, first flip up the armrest then pull the lever (arrowed) and the armrest can be removed by pulling upwards on the tubing.

## 3. Quick Release Wheel.

On the self propel model, the rear wheels can be removed. To remove the rear wheel, push the button in the centre of the wheel hub and slide the wheel from its axle.

## 4. Half Folding Back. Follow the previous instructions to fold the back.

## 5. Folding the wheelchair.

Remove the seat and back cushions. Then grab the centre of the front and rear edges of the seat sling. Pull upwards on the seat sling and the wheelchair should naturally fold up.

*See back page for details on restraining the wheelchair in a motor vehicle.*

## using the stepper tube

Use the stepper tube to raise the front castors (when mounting a kerb for example). To use, push down on the stepper tube with a foot. Do not raise the front castors by pushing down on the push handles as this could result in damage to the wheelchair.

**To mount a kerb.** Approach the kerb head on. Then the attendant uses the stepper tube to raise the front castors, and lowers the front castors on the raised kerb. Finally the attendant should push the wheelchair forward, lifting it up slightly to mount the kerb if required.

**To go down a kerb.** Line up the front castors with the edge of the kerb. The attendant uses the stepper tube to raise the front castors and tip the user slightly back. Keeping the castors raised, slowly lower the wheelchair down the kerb.

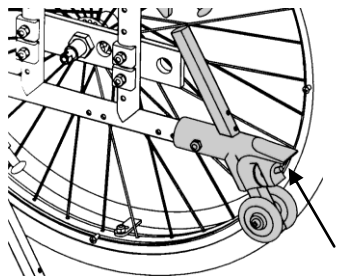

### Adjusting Anti-Tip Wheel Height

The stepper tube comes with an integral anti-tip wheel. To adjust the height of this wheel pull the metal disc (arrowed) and move the wheel to the correct height, and release.

*Warning: When going down a kerb, the front castors must be raised to prevent the user from falling out. The above are only recommendations and may not be suitable for all events / users.*

## brake operation

### Parking Brakes

To apply the parking brakes, push the handle on the brake unit until locked in place. To release the brake, push the handle in the opposite direction. The brakes should always be applied when the wheelchair is stationary.

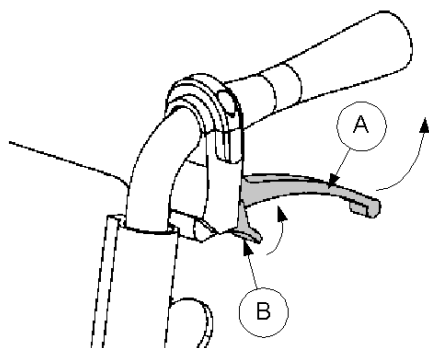

### Cable Brakes

On the transit model, the attendant pushing the wheelchair may use cable-operated brakes to slow or park the wheelchair. To apply the brakes, squeeze the large lever (A) on the push handles and the brakes will be applied. The brakes will remain applied until the small lever (B) on the brake handle is pressed to release the lever.



### Before Using the Wheelchair read the safety notices below:

- Use slow speeds on gradients. Do not exceed the maximum gradient stated.
- The wheelchair is only suitable for single occupancy.
- Keep your feet on the footplates when moving. Do not stand on the footplates.
- Do not use escalators.
- Do not reverse down a gradient
- Maintain proper balance at all times. Users should not move their centre of gravity out of the seating area.
- Do not reach for items further than your arm will extend.
- Be aware of hazards in your environment, such as narrow doorways, steps, household appliances, children's toys, etc.
- We recommend you consult your healthcare professional for advice about transferring to and from the wheelchair. The parking brakes should always be applied when transferring.
- Ensure that fingers and objects do not get caught in the spokes of the rear wheels.

The transit wheelchair can only be propelled by an attendant. The attendant should push the wheelchair from behind using the handgrips, and following the safety advice above.

The self propel wheelchair can be propelled by an attendant (as directed above) or the wheelchair user. The user can propel themselves by pushing on the handrims attached to the side of the rear wheels, and slow themselves down by applying pressure to the handrims.

When stationary the brakes should always be applied.

## care and maintenance

- Before each use of the wheelchair, the brakes and tyres should be checked.
- The wheelchair should be stored in a dry environment, away from direct sunlight. When in storage the wheelchair can be folded up
- The wheelchair should be kept clean and dust free. This can be done with a duster or damp cloth.
- The user should routinely check the following items. It is recommended that a Drive Medical dealer services the wheelchair annually, where these items should be repaired, replaced, adjusted and/or lubricated if required:
  - Tyre wear
  - Wheel bearings
  - Castors
  - Brakes
  - Legrest locking mechanism
  - Seat upholstery
  - Back upholstery
  - Arm pads
  - Rear wheel quick release pin
  - Half folding back mechanism
  - Back posts
  - Wheelchair (folds up)

## powerpack installation



This wheelchair is suitable for some retrofit powerpacks, such as the PowerStroll. A suggested configuration is shown left.

Note this is a suggestion, and the mounting position will need adapting to be suitable for the user and the powerpack used. For more information about the PowerStroll contact your Drive Medical dealer or visit [www.drivemedical.co.uk](http://www.drivemedical.co.uk) for more details.



## specification

	Self Propel	Transit
Dimensions *1 L x W1/W2/W3 x H	103 x 58/63/68cm x 93cm 40" x 23 - 27" x 37"	92 x 58 / 63 / 68cm x 93cm 37" x 23 - 27" x 37"
Dimensions *2 (L x W x H)	83cm x 26cm x 63cm 33" x 10" x 25"	83cm x 26cm x 63cm 33" x 10" x 25"
Seat W1/w2/w3 x D x H	40/45/50cm x 42cm x 52cm 16"/18"/20" x 17" x 20.5"	40/45/50cm x 42cm x 52cm 16"/18"/20" x 17" x 20.5"
Wheel Spacing	43cm - 51cm /17" - 20"	43cm - 51cm / 17" - 20"
Armrest Height	71 - 82cm / 28" - 32"	71 - 82cm / 28" - 32"
Max Gradient	10°	10°
Max User Mass	135kg / 21 stone	135kg / 21 stone

*All dimensions are based on the wheelchair in its default configuration.*

*Dimensions \*1 refers the wheelchair assembled*

*Dimensions \*2 refers to the wheelchair folded and parts removed*

*Weight \*1 is the total weight*

*Weight \*2 is the weight without removable components*

*We reserve the right to change designs and specifications.*

*W1 refers to 16" model, W2 to 18" model and W3 to 20" model*

## warranty

Your Drive branded product is warranted to be free of defects in materials and workmanship for one year from date of purchase. This device was built to exacting standards and carefully inspected prior to shipment. This warranty is an expression of our confidence in the materials and workmanship of our products and our assurance to the customer.

In the event of a defect covered by this warranty, we will at our option supply parts or replace the device. This warranty does not cover device failure due to owner misuse or negligence, or normal wear and tear. The warranty does not extend to non-durable components, such as rubber accessories, castors and grips, which are subject to normal wear and need periodic replacement. The wheelchair frame has a 5-year warranty.

If you have any queries or require full warranty conditions, please contact your Drive stockist.

**Drive Germany:**

**Drive Medical GmbH & Co. KG**  
Leutkircher Straße 44  
D-88316 Isny/Allgäu (Germany)

**Web** [www.drivemedical.de](http://www.drivemedical.de)

**Drive UK:**

**Drive Medical Limited**  
Ainley's Industrial Estate, Elland.  
UK WEST YORKSHIRE HX5 9JP

**Web** [www.drivemedical.co.uk](http://www.drivemedical.co.uk)

## spare parts available

The following spare parts are available for your wheelchair. For frames and cross brace replacements contact your Drive Medical dealer.

Z17180-01: Plastic cross brace support

Z17205-01A: Seat canvas

Z17250-01: Back canvas

Z17325-01SIL: Push handle

Z17350-01: Half fold mechanism

Z17400-01: Castor wheel and fork

Z17425-01: Castor housing

Z17450-01: Quick release pin for 24" wheel

Z17460-01ST: 24" rear wheel

Z10480-01ST: 12.5" rear wheel

Z17530-01: RHS adjustable arm rest

Z17580-01: LHS adjustable arm rest

Z17600-01SIL: LHS leg rest

Z17650-01SIL: RHS leg rest

Z17800-01: Anti-tip wheel

Z17705-01: LHS brake (for 24" wheel)

Z17755-01: RHS brake (for 24" wheel)

EB004-01: Brake set (for 12.5" wheel)

The parts are available exclusively from Drive Medical stockists. To order the parts please visit the stockist where you bought the wheelchair or visit [www.drivemedical.co.uk](http://www.drivemedical.co.uk) to find your local stockist. Spare part catalogues and other documentation can also be found at [www.drivemedical.co.uk](http://www.drivemedical.co.uk)

## using the wheelchair as a seat in a motor vehicle

This Enigma wheelchair has been tested to Wheelchair Crash Test standard ISO 7176/19 using restraints from Q-Straint. Wherever possible the wheelchair user should use the vehicle's fitted seats and the wheelchair should be folded away and placed safely in the luggage compartment of the vehicle or restrained.

If it is not feasible to transfer to the vehicle's seat then the Enigma wheelchair may be used as a chair whilst the vehicle is moving with the necessary restraints and with the wheelchair facing the front of the vehicle. Drive Medical recommends that the following types of restraints be used:

- a) **Buckle and tongue or standard hook restraints for the front of the wheelchair,**
- b) **'J' restraints for the rear of the wheelchair,**
- c) **3-point harness for the user restraint.**

The lap belt should be worn across the front of the pelvis, with the webbing fed between the back posts and armrest.

The upper torso belt should be worn over the shoulder. The belt should be worn as firm as possible without being uncomfortable. Ensure the webbing is not twisted. For more information on restraints please contact Drive Medical. Below is a diagram illustrating the recommended positions for the restraints. The securement points for the restraints are marked on the wheelchair using the symbol (below right).

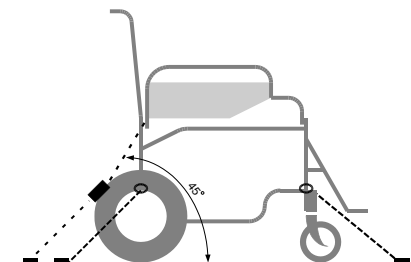

### LEGEND

- Wheelchair Restraints
- Occupant Restraints

